

INTERMEDIATE * SHOWMANSHIP * BRONZE

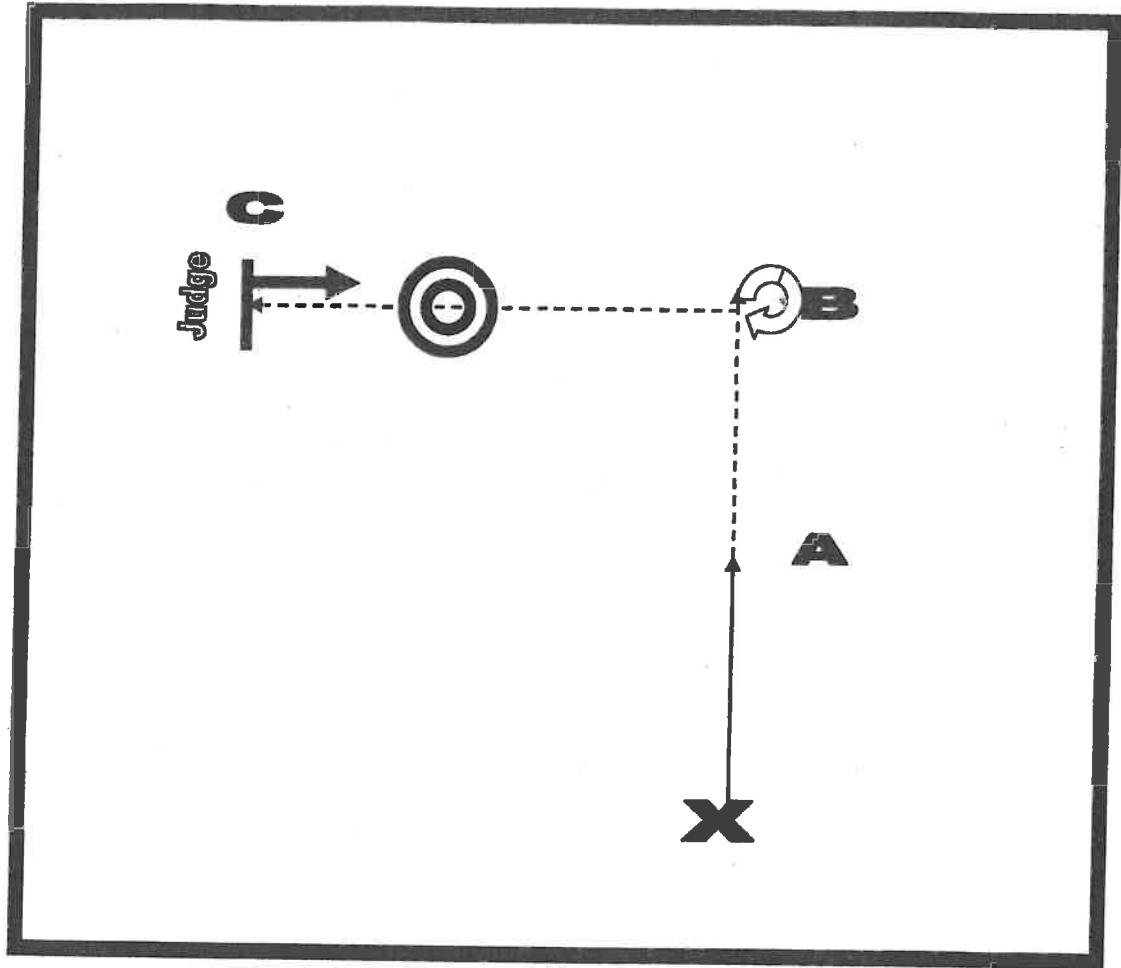

1. Wait at X. When acknowledged, walk to A.
2. Trot to B. Halt.
3. Perform a 270-degree right haunch turn.
4. Trot to C. Halt and wait 5 seconds.
5. Back 5 steps.
6. Perform a 45-degree right haunch turn.
7. Stop and set-up for inspection.
8. When dismissed, trot to line.

INTERMEDIATE * SHOWMANSHIP * SILVER

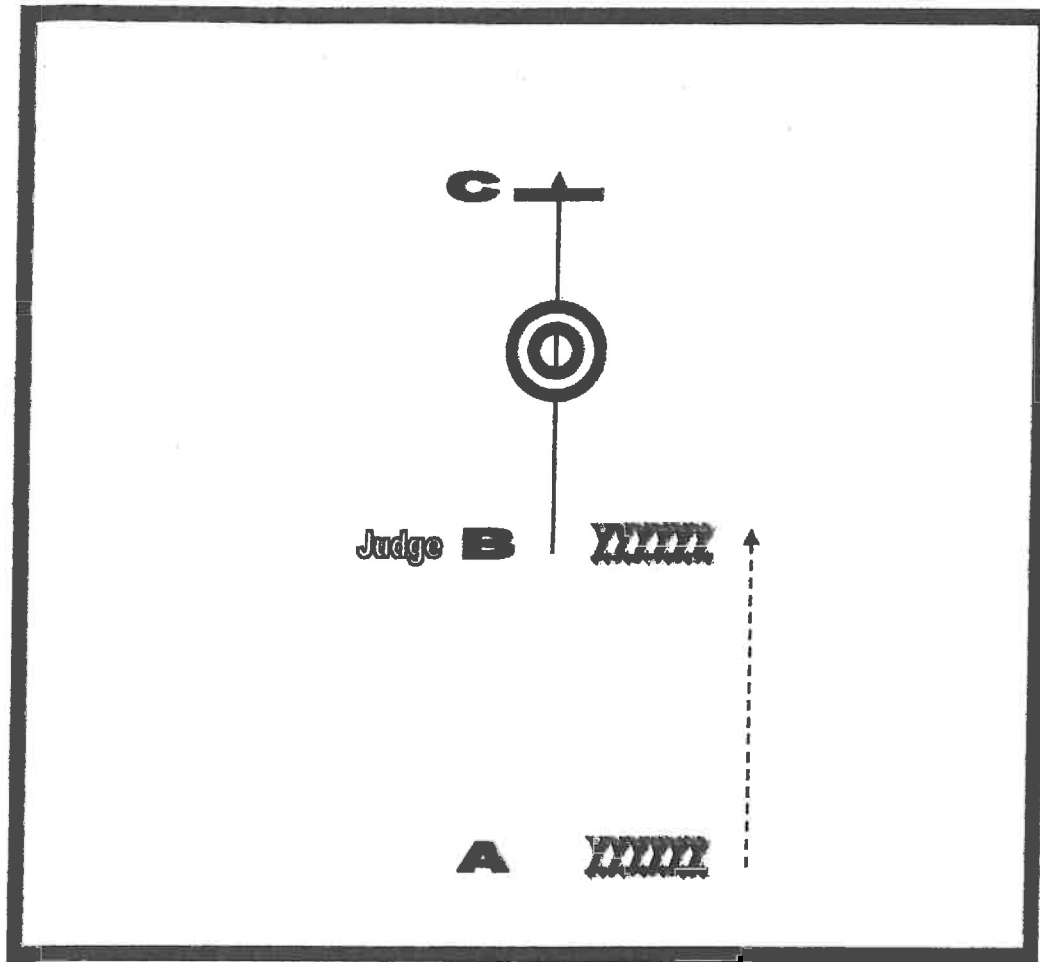

1. Wait at A. When acknowledged, sidepass 6 steps to the right (3 cross-over steps).
2. Trot until even with B.
3. Move to the off side of your horse. Sidepass 6 steps to the left (3 cross-over steps).
4. Stop and set-up for inspection.
5. When dismissed, walk half way to C. Perform a 360-degree right haunch turn. Continue walking to C.
6. Halt. Wait to be dismissed.

INTERMEDIATE * SHOWMANSHIP * GOLD

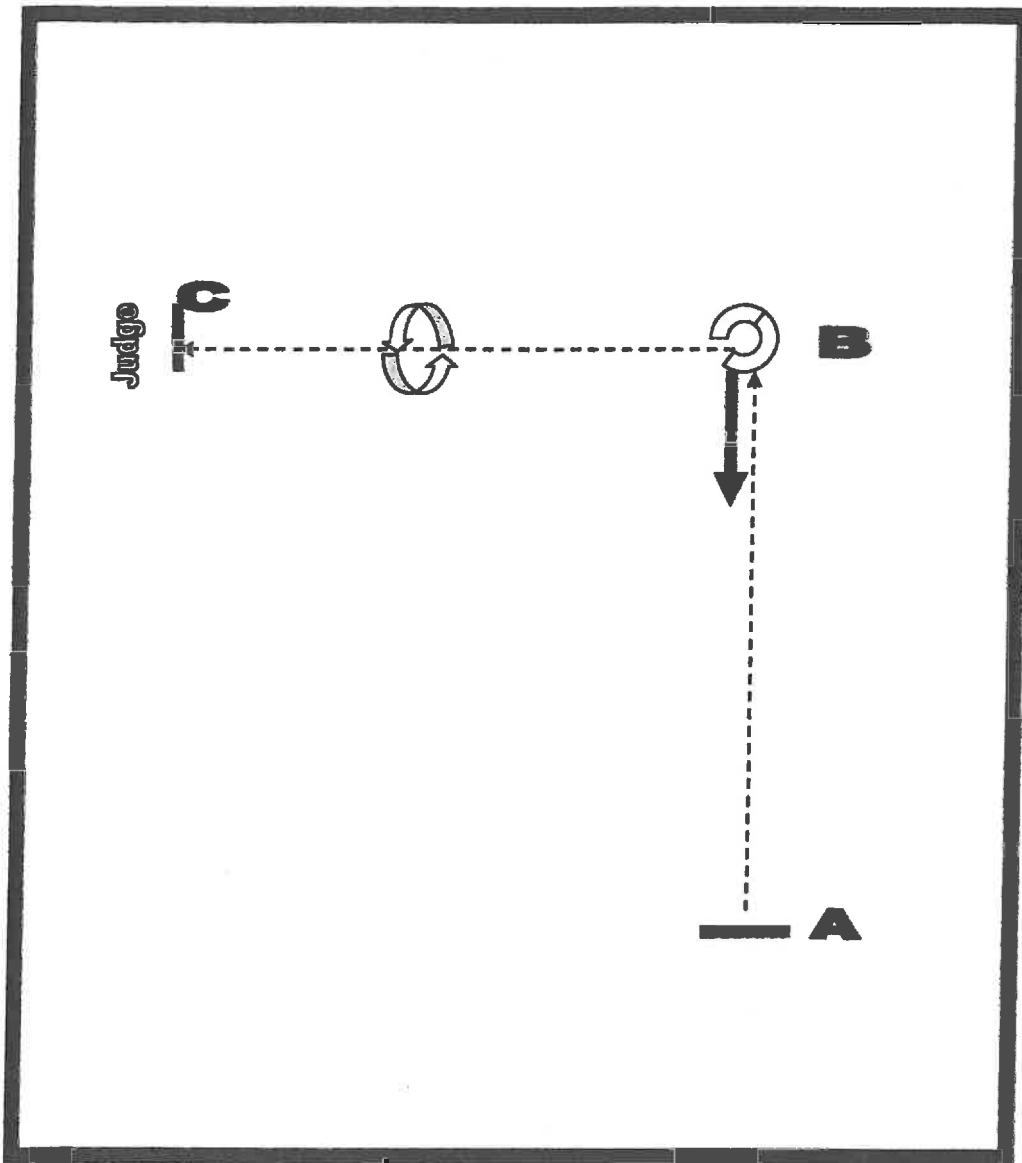

1. Wait at A. When acknowledged trot to B. Halt.
2. Back 7 steps and close.
3. Perform a 270-degree right haunch turn.
4. Trot $\frac{1}{2}$ way to C. Halt.
5. Move to the offside; perform a 360-degree right forehand turn. Continue to stay on offside and trot to C. Halt.
6. Set-up for inspection
7. Judge will ask question.
8. When dismissed return to nearside and continue to line.

INTERMEDIATE * HUNT SEAT * BRONZE

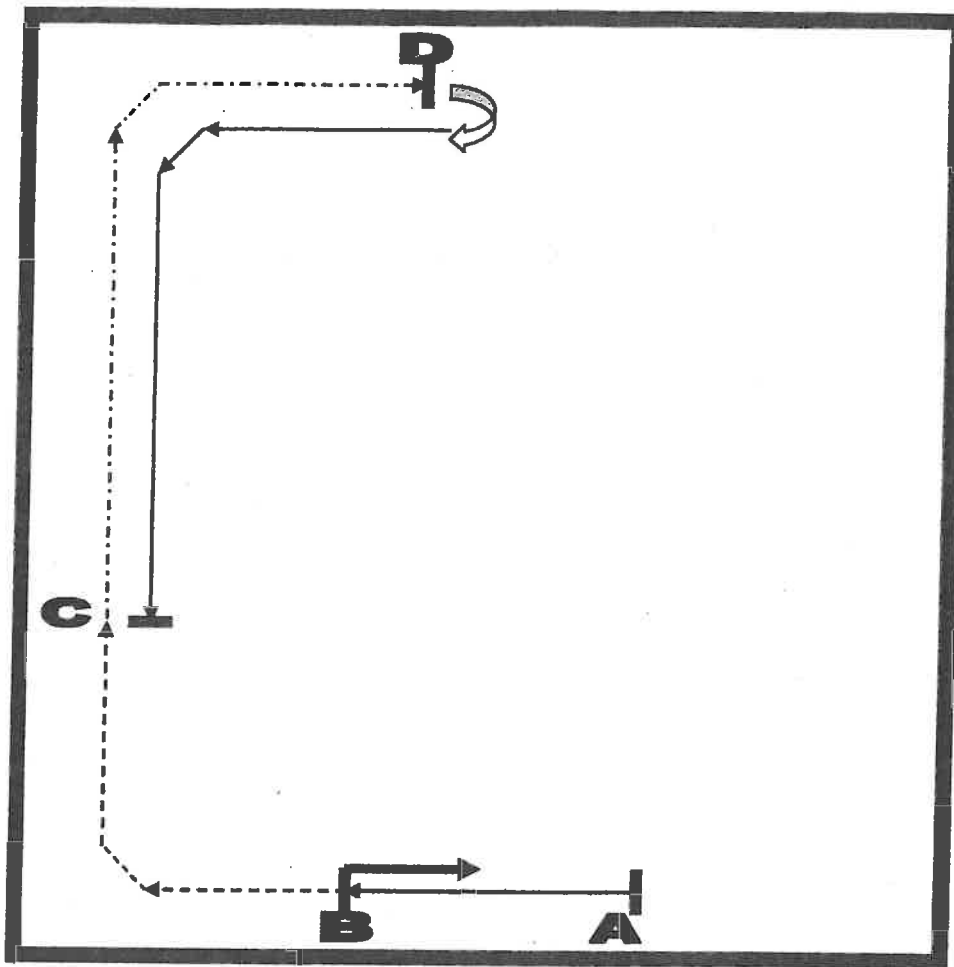

1. Wait at A.
2. When acknowledged proceed to at a walk on the right track.
3. At B, Halt. Back 5 steps.
4. Pick-up a sitting trot and trot around corner.
5. At C, pick-up posting trot showing correct diagonal. Halt at D.
6. Reverse at the walk. Pick-up canter and showing correct lead and return down rail to C.
7. Halt. Address judge and wait to be excused.

INTERMEDIATE * HUNT SEAT * SILVER

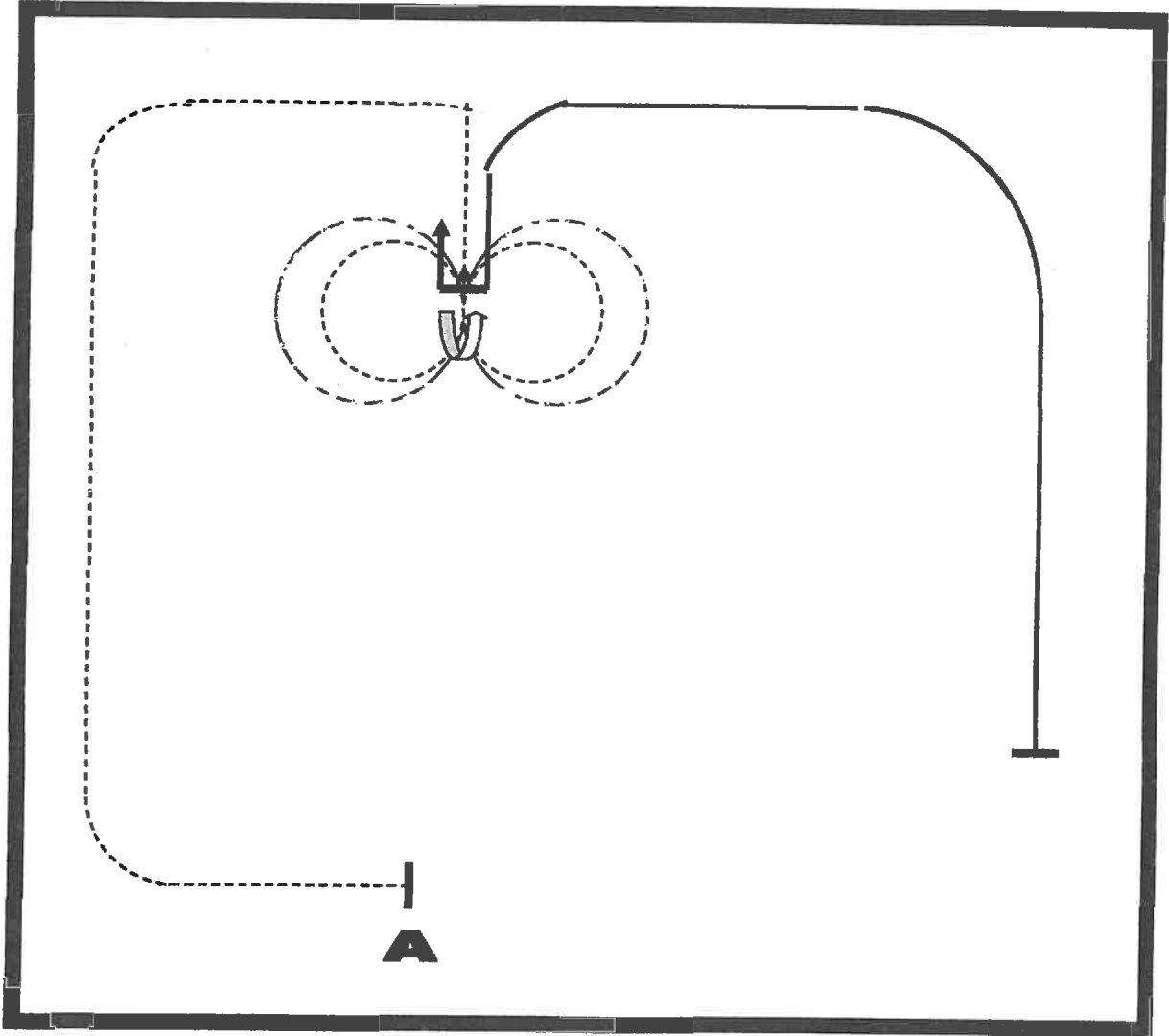

1. Wait at A.
2. When acknowledged, pick up a sitting trot. Trot down the rail to the end of the ring, turning into center of figure-8 as shown.
3. Trot a figure-8 at a sitting trot.
4. Pick up a posting trot. Trot a figure-8 starting to the right showing one diagonal change.
5. Halt. Back 5 steps and close.
6. Perform a 180-degree right forehand turn.
7. Pick up a canter showing the correct lead and canter to the rail and around the corner.
8. After corner, hand gallop 3/4s of the way down the rail.
9. Halt. Address judge and wait to be excused.

INTERMEDIATE * HUNT SEAT * GOLD

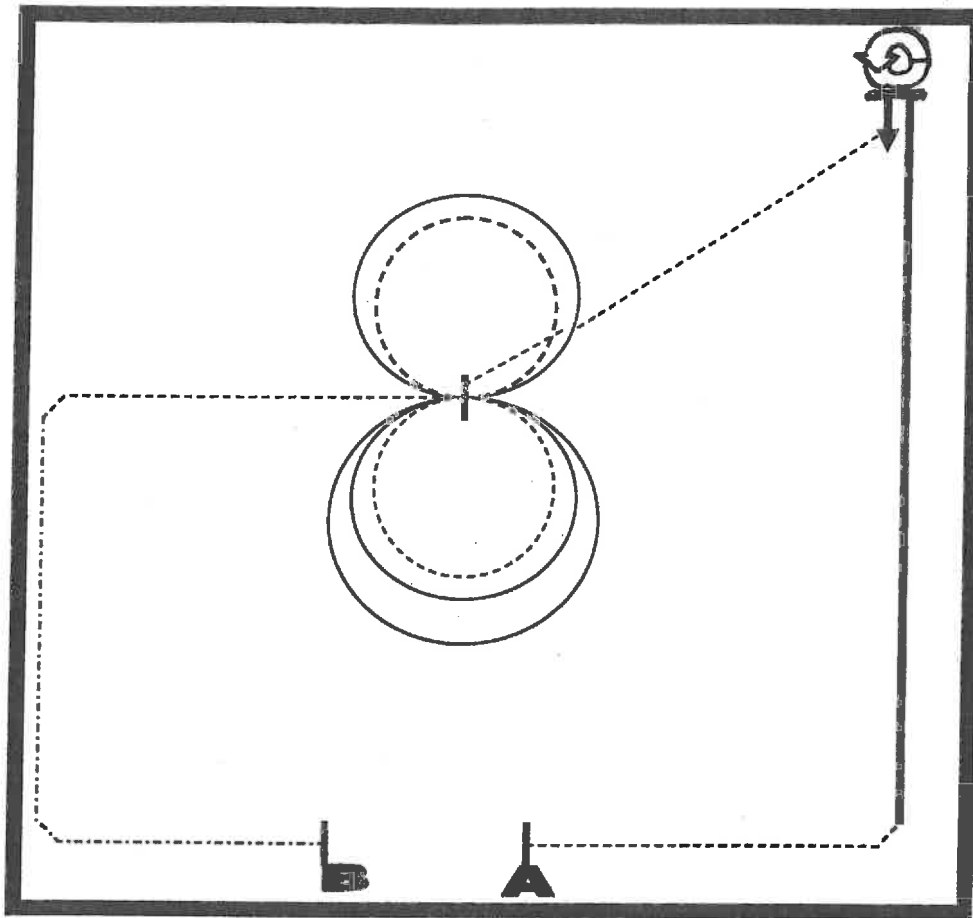

1. Wait at cone A. When acknowledged proceed at a sitting trot left track to the corner.
2. At corner begin canter on correct lead, immediately lengthen to a hand gallop along the rail.
3. Halt before the next corner. Execute a 360-degree left haunch turn and back 5 steps.
4. Do a posting trot to the middle of the arena. Halt.
5. Trot a figure-8 with a diagonal change. Halt.
6. Canter $1\frac{1}{2}$ figure-8s starting to the left with flying lead changes. Halt.
7. Posting trot to rail, turn left, and extend trot to cone B.
8. Halt at cone and stand for 8 seconds.
9. Wait to be excused by judge.

INTERMEDIATE * STOCK SEAT * BRONZE

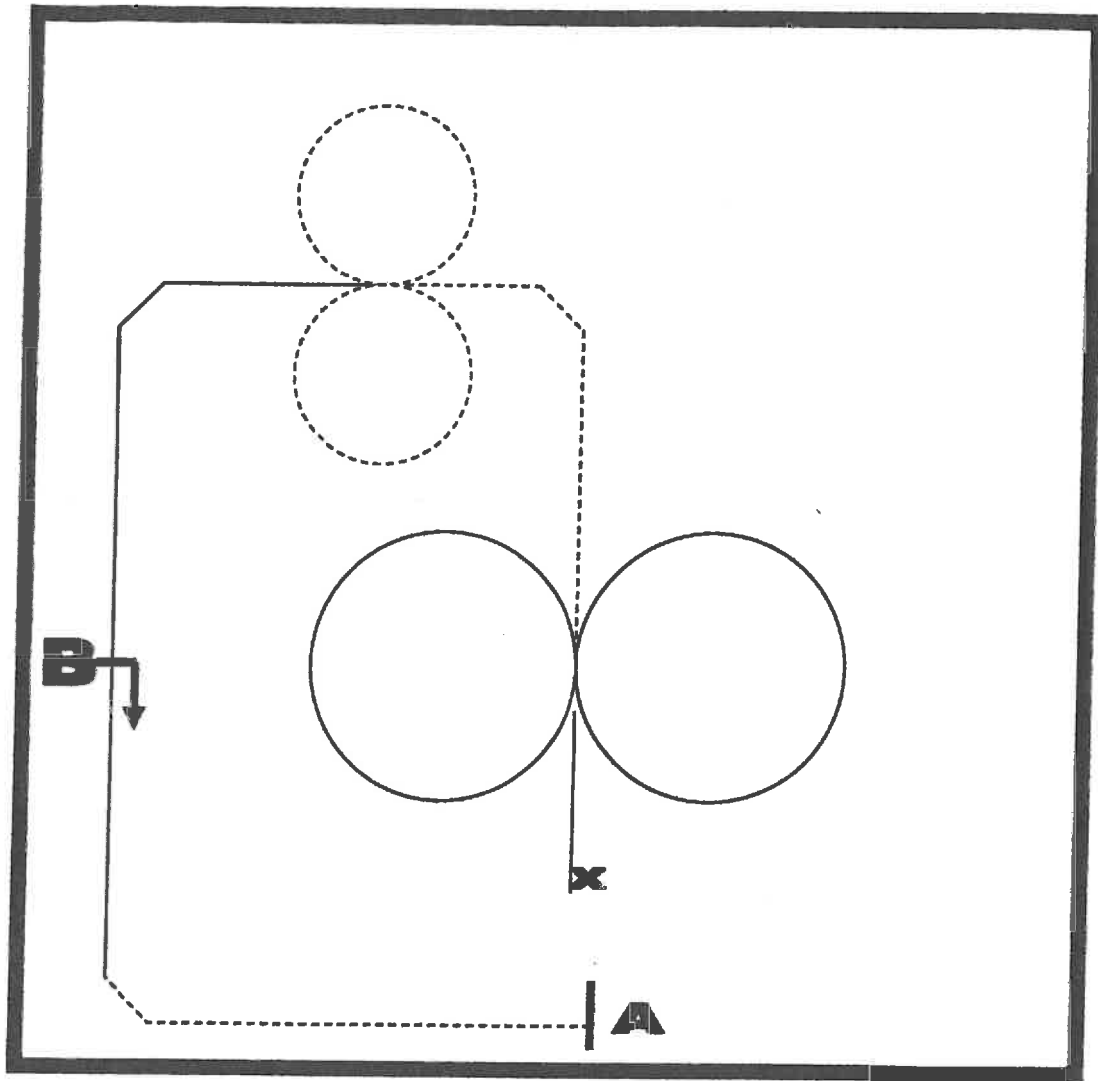

1. Wait at A. When acknowledged proceed at a jog on the right track.
2. As you round the corner, start to lope on the left lead.
3. At cone B halt. Back 6 steps, do not close.
4. Pick-up a lope on the right lead and continue down rail 2/3 of the length of the arena.
5. Curve toward the center of the arena and break down to a jog.
6. Jog a figure-8 starting the right.
7. Continue jogging, curving to go down the middle of the arena.
8. Lope a figure-8 starting to the right, showing a lead change.
9. Break down to a walk, and walk out of the figure-8 ten to fifteen (10-15) feet.
10. Halt, and wait to be dismissed.

INTERMEDIATE * STOCK SEAT * SILVER

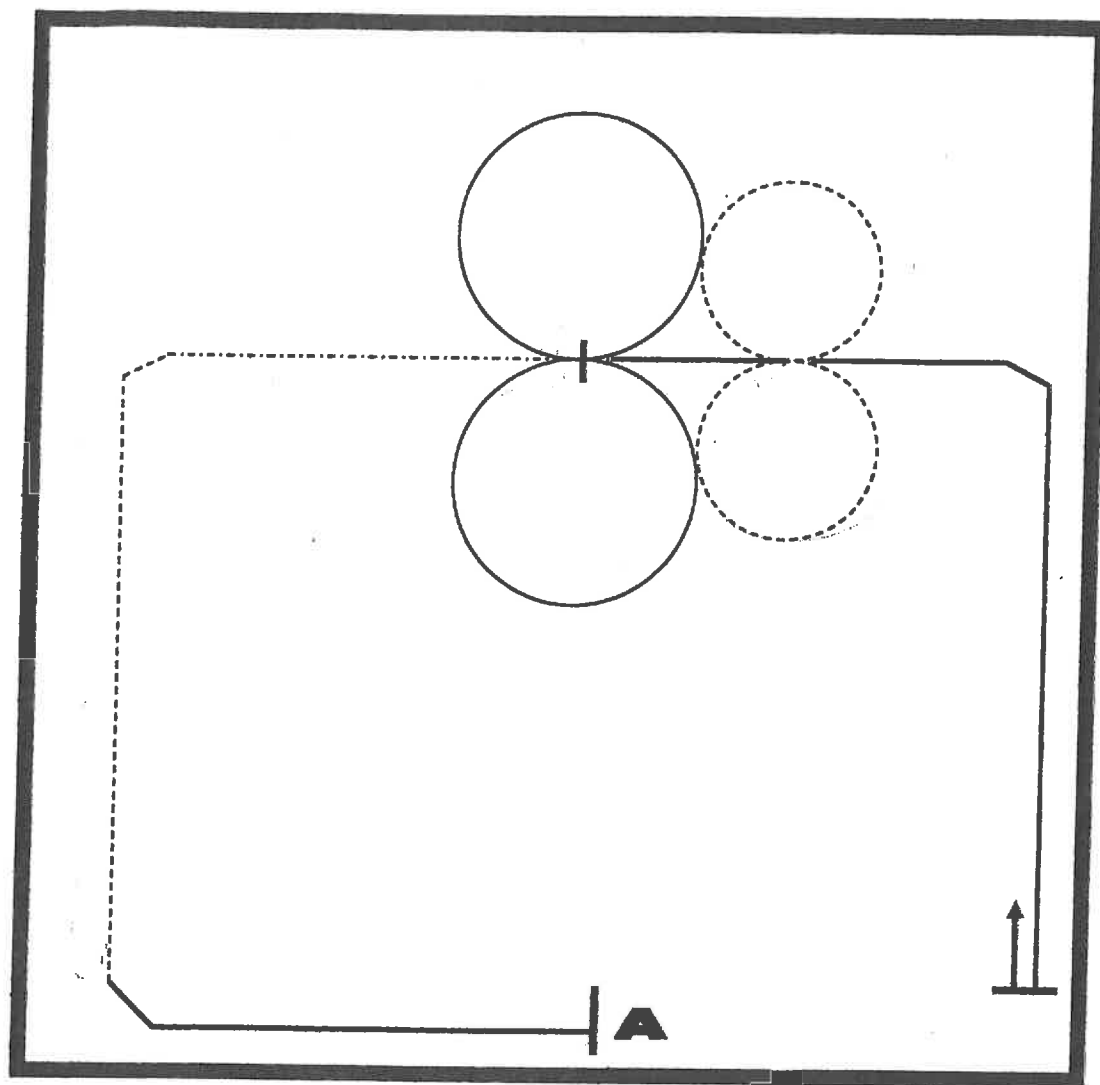

1. Wait at cone A dismounted. When acknowledged, mount your horse.
2. Pick up a lope on the right lead.
3. Just around the corner, reduce your gait to a jog.
4. $2/3$ of the way down the arena, curve to the middle and extend the jog.
5. Halt in center of arena.
6. Lope a figure-8 starting to the right, showing a simple or flying lead change.
7. Continue on the left lead 3 to 6 strides and break to a jog.
8. Jog a figure-8 starting to the right.
9. Lope on right lead to rail and continue lope to corner.
10. Halt and back 7 steps. Wait to be excused by judge.

INTERMEDIATE * STOCK SEAT * GOLD

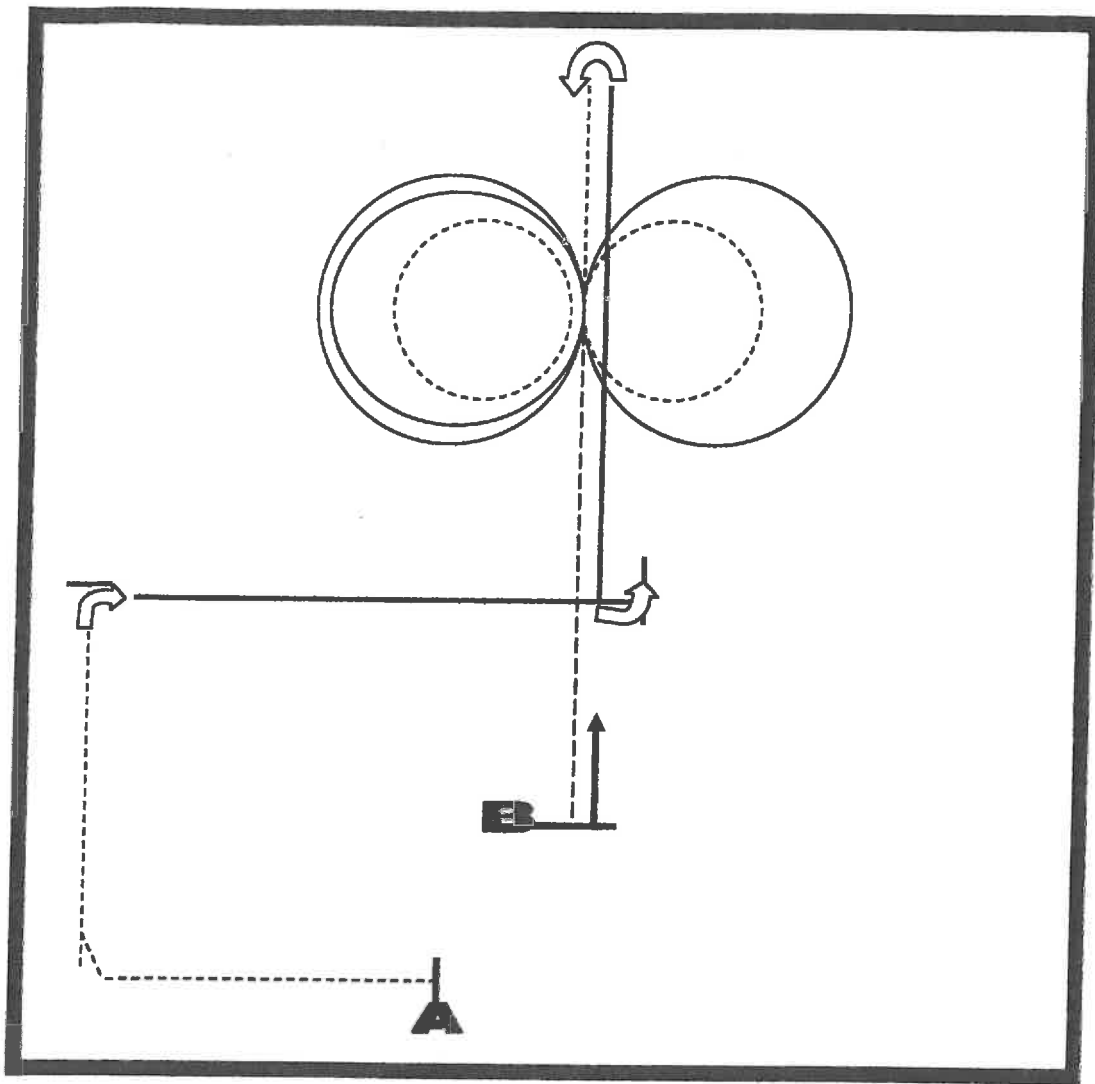

1. Begin at cone A. Pick-up a jog and jog halfway down rail.
2. Halt. Demonstrate a $\frac{1}{4}$ right haunch turn.
3. Lope on left lead to center of arena. Halt.
4. Demonstrate a $\frac{1}{4}$ left haunch turn.
5. Lope on right lead down center of arena.
6. Halt 10 feet from the rail, Halt. Demonstrate a 180-degree left haunch turn.
7. Drop your stirrups and jog $\frac{1}{4}$ of the way down the arena.
8. Jog a small figure-8, then lope a $1\frac{1}{2}$ figure-8's with 2 flying lead changes.
9. Reduce gait to extended jog and jog down center of the arena $\frac{3}{4}$ of the length.
10. Halt. Pick-up your stirrups.
11. Back 11 steps and wait to be excused by judge.

SENIOR * SHOWMANSHIP * BRONZE

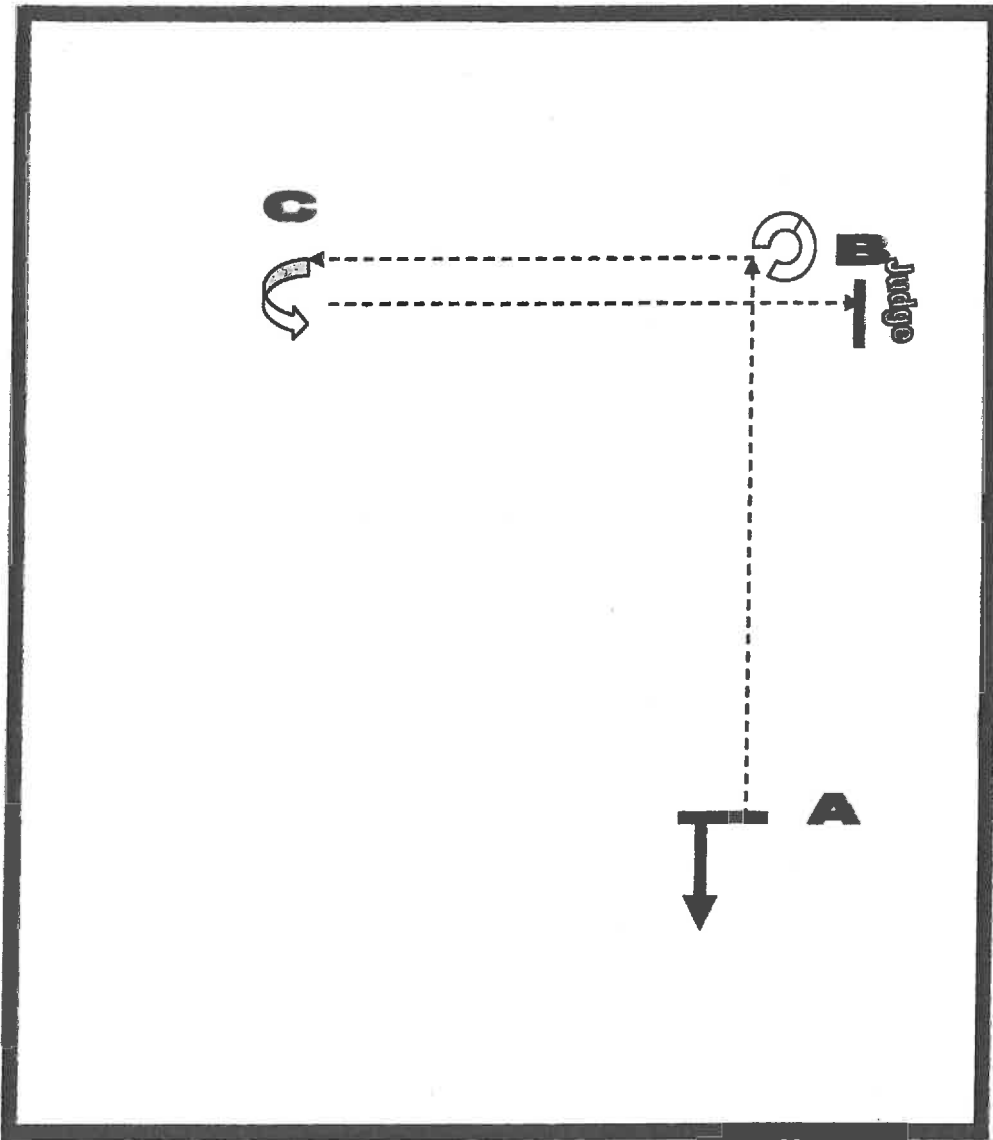

1. Wait at A. When acknowledged, back 7 steps.
2. Trot to B.
3. Perform a 270-degree right haunch turn.
4. Trot to C. Halt.
5. Perform a 180-degree left forehand turn.
6. Trot to B. Halt. Set-up for inspection.
7. When dismissed, walk into line.

SENIOR * SHOWMANSHIP * SILVER

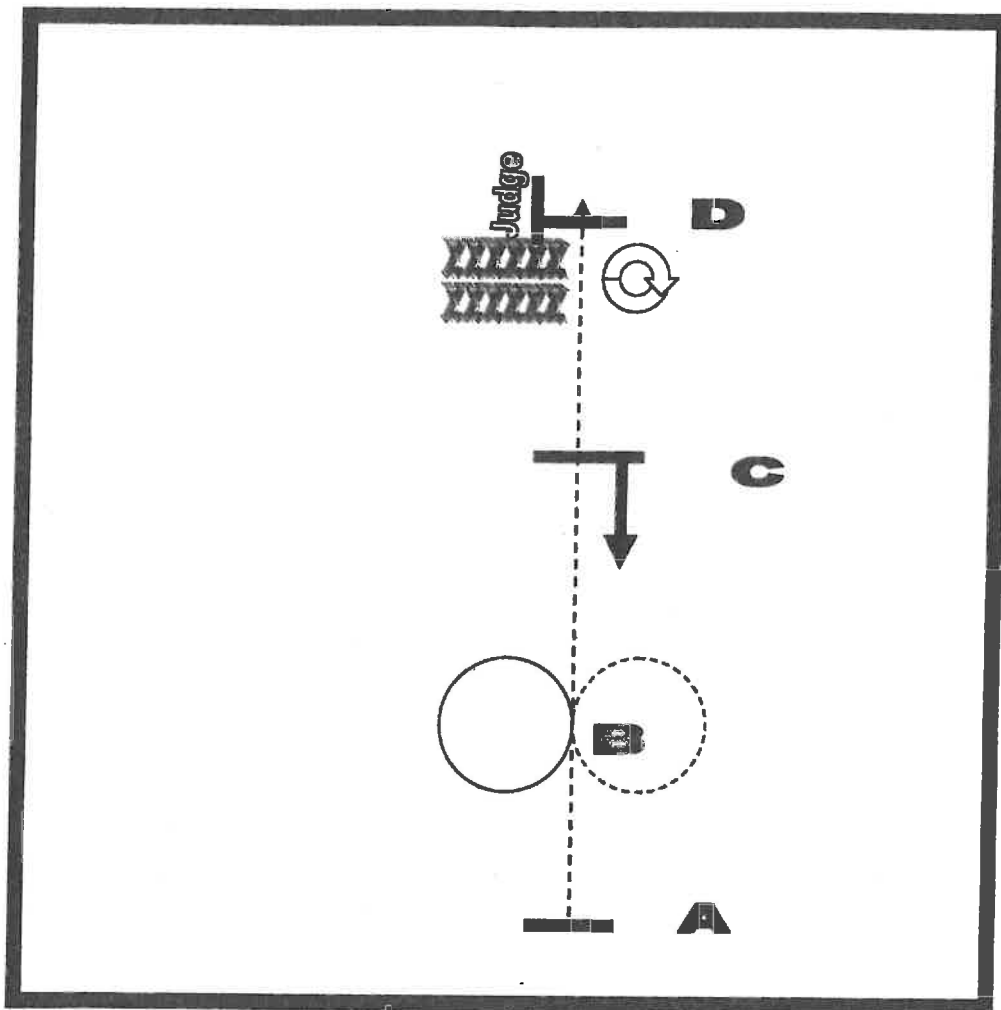

1. Wait at A. When acknowledged trot to B and trot a circle to the right.
2. Walk a circle to the left (forming a figure 8) and trot to C.
3. Halt. Move to the offside of your horse. Back 6 steps.
4. Trot to D. Halt.
5. Sidepass 6 steps to the left (3 cross-over steps).
6. Return to the nearside of your horse and sidepass 6 steps to the right (3 cross-over steps).
7. Perform a 630-degree haunch turn to the right.
8. Set-up for inspection. Answer question.
9. Wait to be excused.

SENIOR * SHOWMANSHIP * GOLD

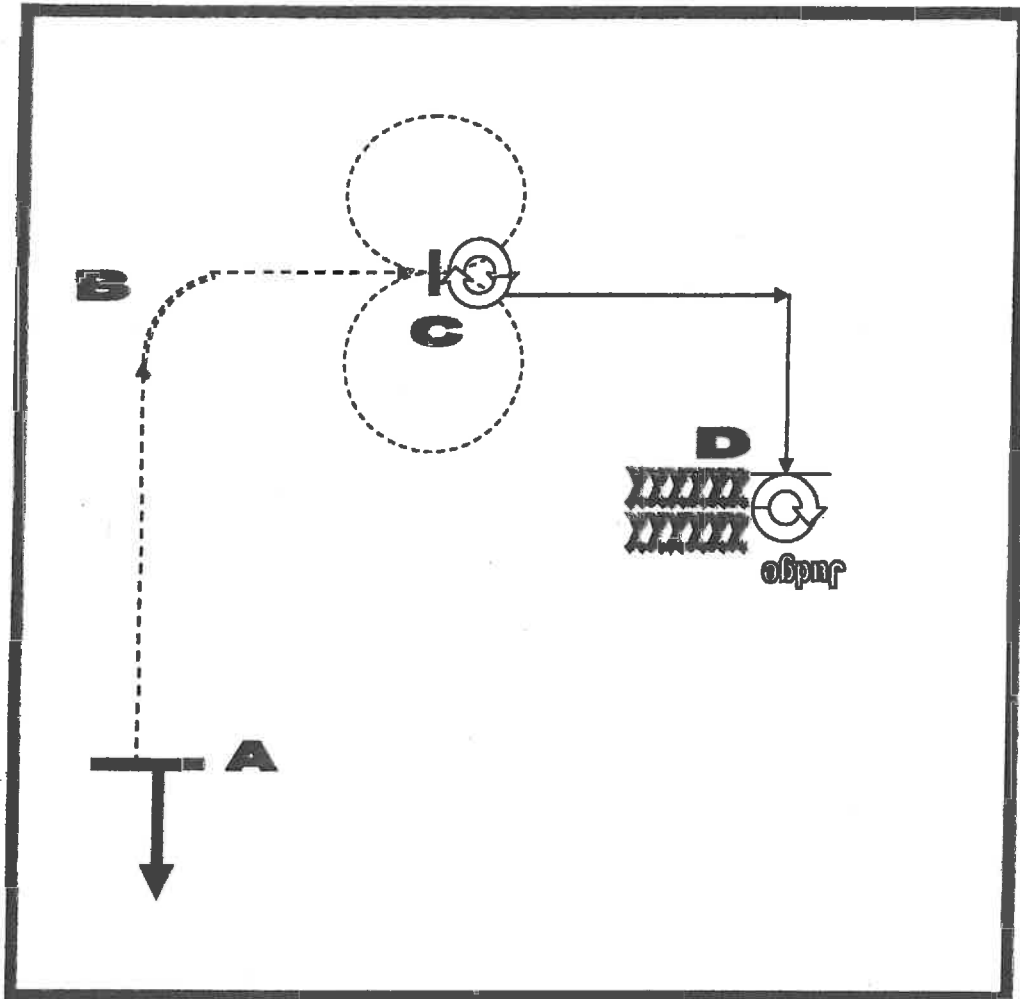

1. Wait at A. When acknowledged back 11 steps.
2. Immediately show a brisk trot down the rail.
3. Turn right at B, continue to C, show a distinction to a slow trot and trot a figure-8 starting to the right. Halt.
4. Move to the offside of your horse.
5. Perform a 360-degree right forehand turn.
6. Walk to D. Halt. Set up for inspection.
7. Answer question.
8. Return to nearside of your horse.
9. When acknowledged, sidepass right 6 steps (3 crossovers), then sidepass left 6 steps (3 crossovers).
10. Return to the nearside of your horse and execute a 360-degree right haunch turn.
11. Wait to be dismissed.

SENIOR * HUNT SEAT * BRONZE

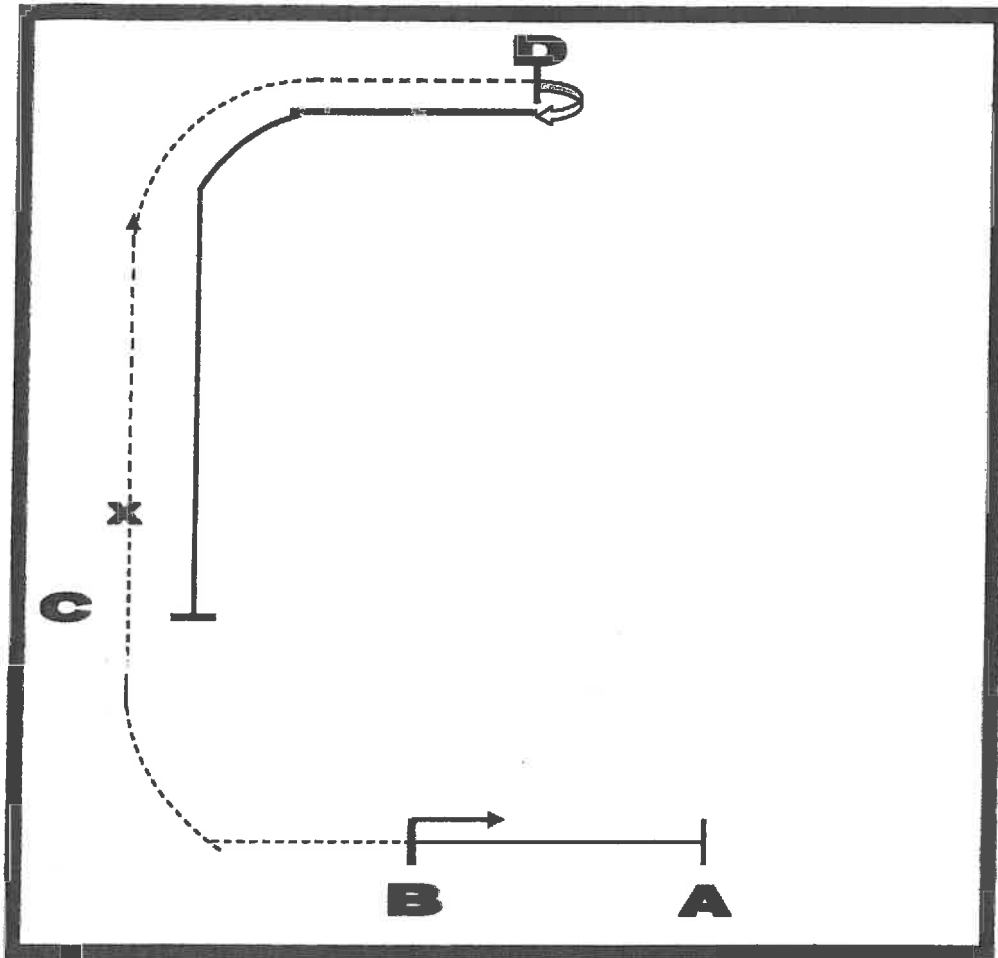

1. Wait at A.
2. When acknowledged proceed at a walk to B. Halt.
3. Back 5 steps.
4. Drop irons and pick up a sitting trot around corner.
5. Pick up a posting trot showing correct diagonal halfway down rail and around corner. Halt at D.
6. Reverse at walk.
7. Pick up irons.
8. Pick up canter showing correct lead and return down rail to C. Halt.
9. Address judge and wait to be dismissed.

SENIOR * HUNT SEAT * SILVER

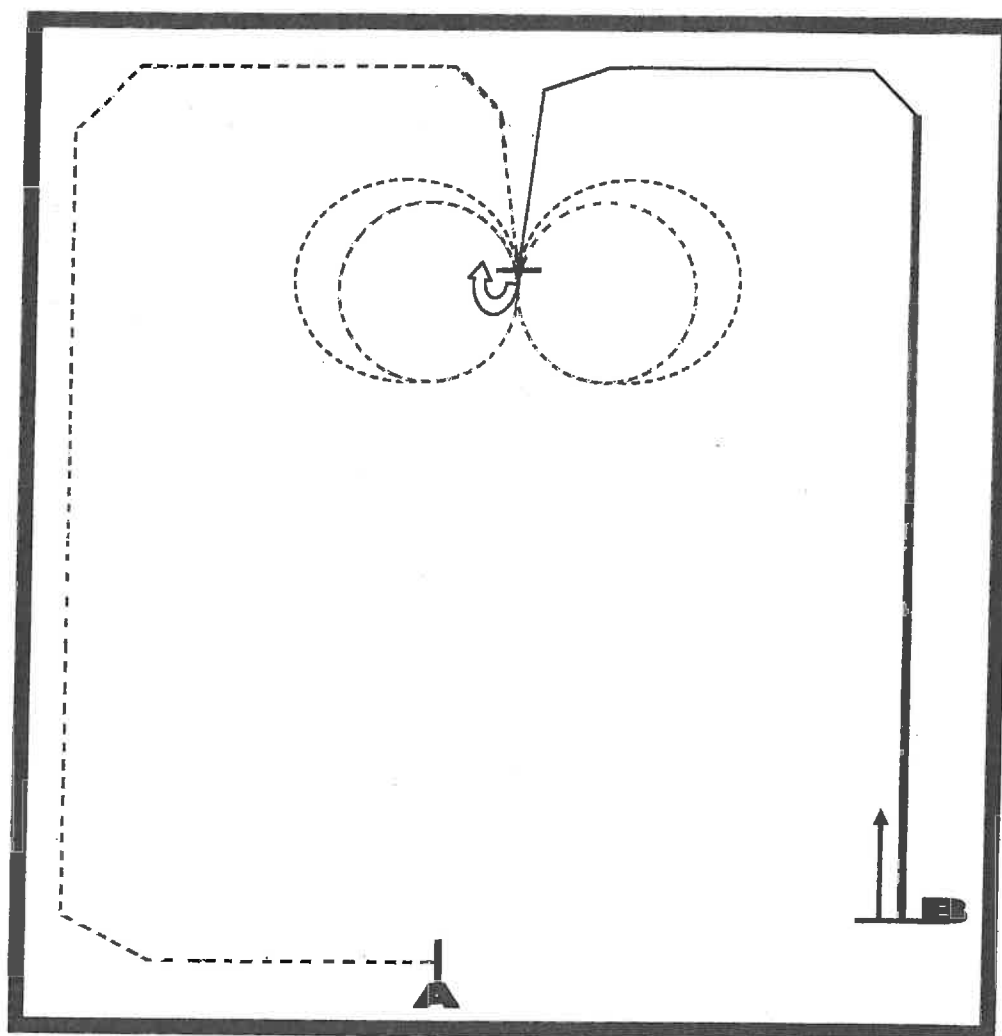

1. Wait at A.
2. Pick up a sitting trot and trot down the rail to the end of the arena, stopping in the center of figure-8. Halt.
3. Drop irons. Execute a figure-8 at a sitting trot, starting the left and showing correct diagonals. Halt.
4. Execute a figure-8 at a posting trot with a diagonal change. Halt.
5. Pick up irons. Execute a 180-degree right forehand turn.
6. Pick up a canter showing correct lead and canter to rail. Continue around corner of arena.
7. After corner, hand gallop to B. Halt.
8. Stand quiet for 5 seconds. Back 5 steps.
9. Wait to be excused by judge.

SENIOR * HUNT SEAT * GOLD

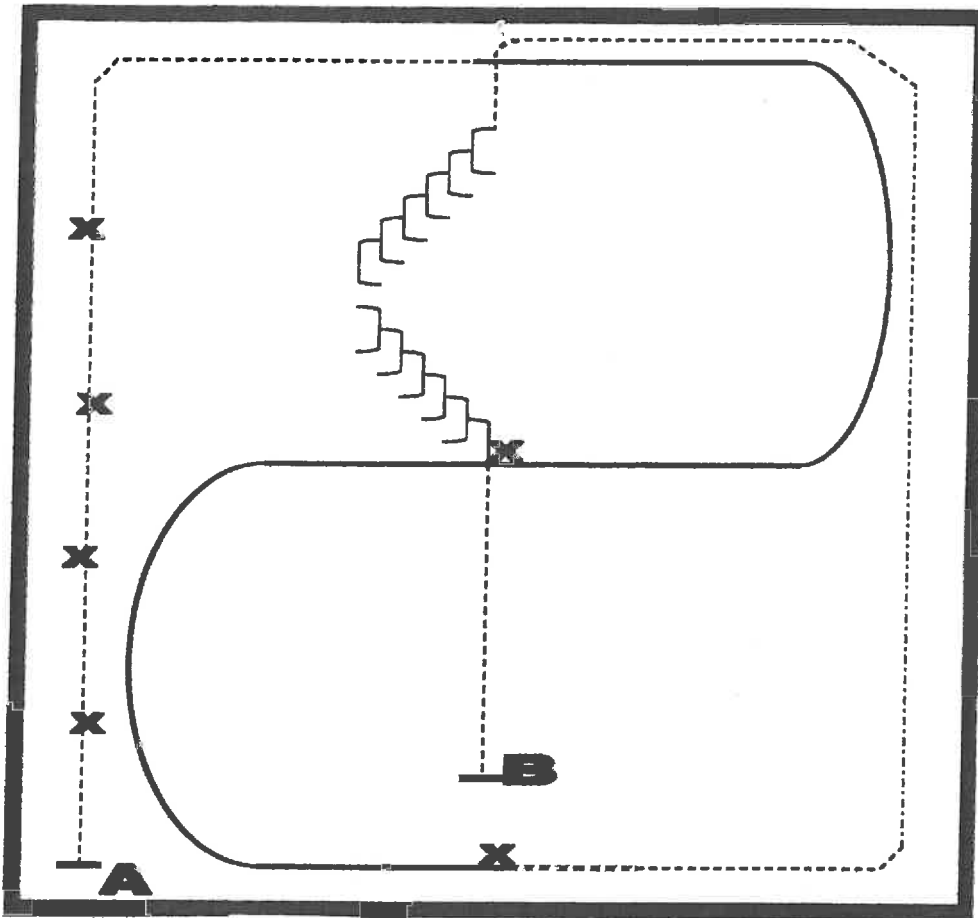

1. Wait at A. When acknowledged, pick up a posting trot on the correct diagonal.
2. Change diagonals 4 times every four strides down the rail. Continue posting trot around corner to centerline.
3. At centerline, pick up a canter on the correct lead and continue around to center of the arena. Execute a flying lead change. Continue around arena and execute another flying lead change.
4. At cone B, break down to a posting trot and continue around corner. Move into an extended trot along rail. At corner, slow to a posting trot.
5. Continue posting trot to centerline and then begin a two-track to the right six (6) crossover. After completing, move directly into a two-track to the left six (6) crossover, coming back to centerline.
6. Continue posting trot down centerline. Halt at cone B.
7. Stand 6 seconds and wait to be dismissed by judge.

SENIOR * STOCK SEAT * BRONZE

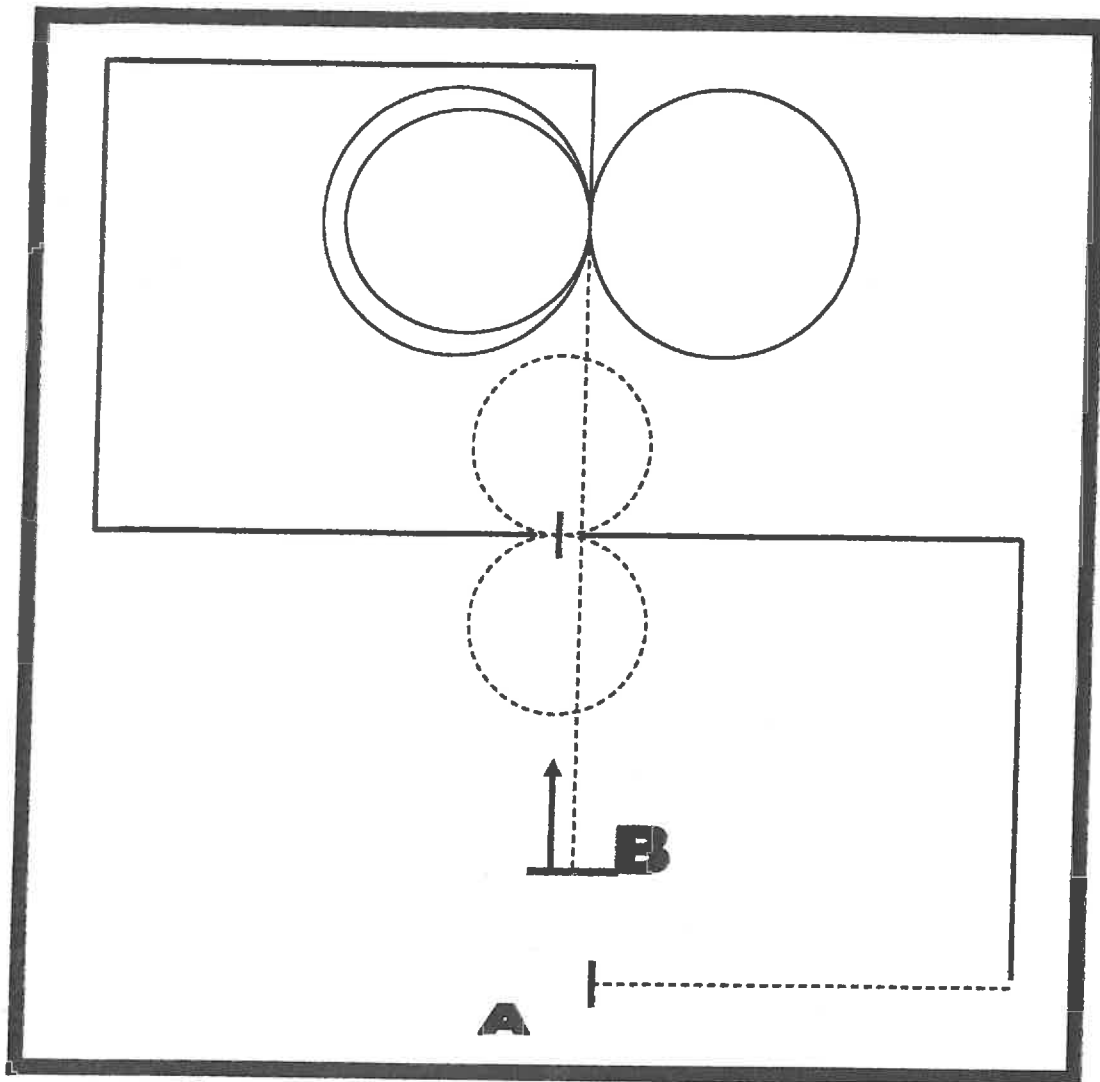

1. Wait at cone A. When acknowledged, pick up a jog.
2. Before the corner, pick up a lope on the left lead.
3. Halfway down the rail, turn left and lope to the center of the arena.
4. Break down to a jog and jog a circle to the right. Halt.
5. Jog a circle to the left.
6. Lope on the right lead to the rail and continue down the right track.
7. Continue into 1^{1/2} figure-8s starting to the right. Complete two lead changes, type of changes optional.
8. After completing figure-8s, break down to a jog. Jog down the center of the arena. Halt at cone B.
9. Back 7 steps and wait to be excused by judge.

SENIOR * STOCK SEAT * SILVER

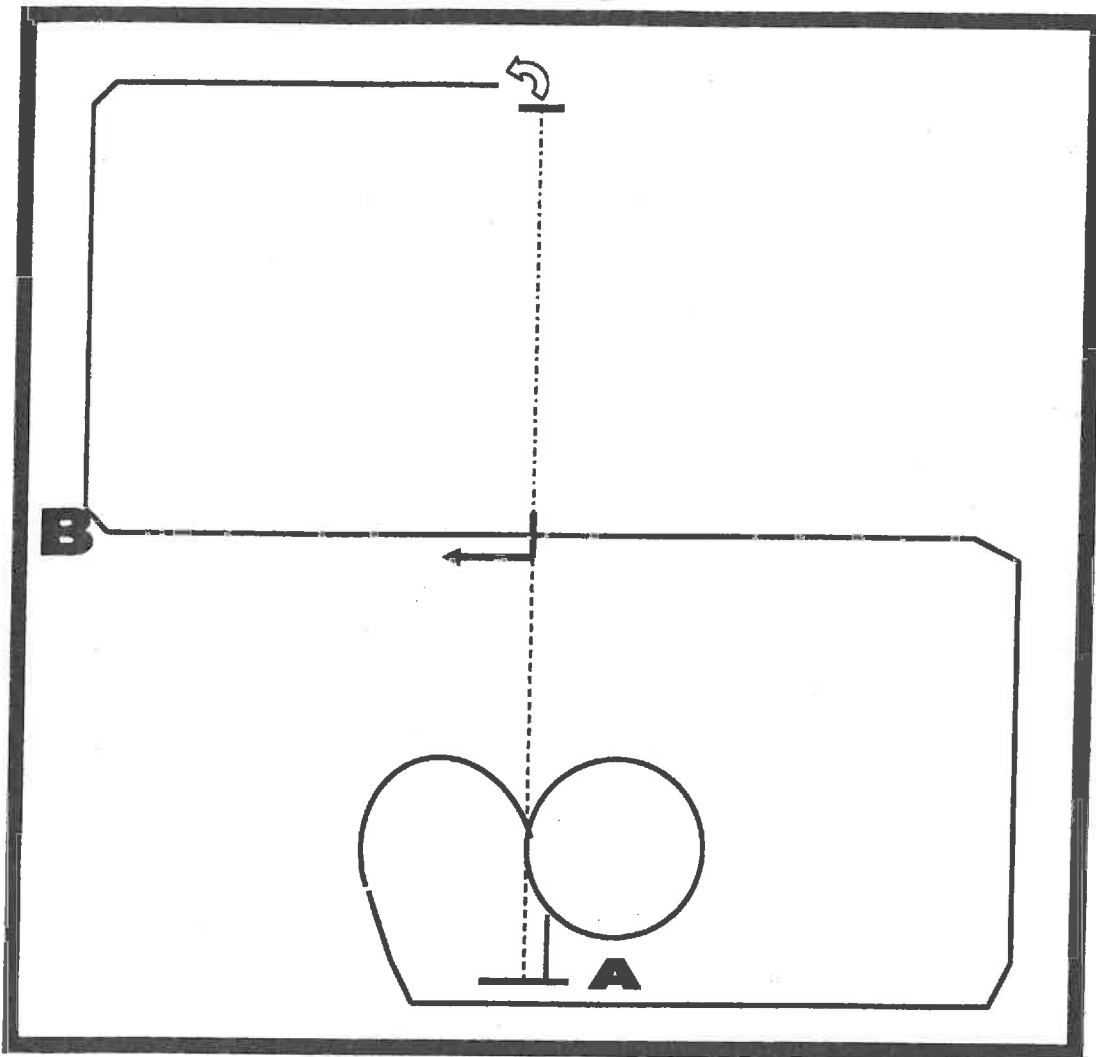

1. Wait at cone A. When acknowledged, drop your stirrups and jog a straight line up the centerline of the arena.
2. At the center of the arena extend the jog.
3. Stop 20 feet from the rail. Pick up stirrups.
4. Execute a 90-degree left haunch turn.
5. Lope on the left lead around corner. At cone B turn and continue loping to the center of the arena. Halt.
6. Back 5 steps and close.
7. Lope on the left lead towards the rail, counter canter around the corners, change lead (simple or flying) at cone A and continue down the rail.
8. Past cone A, begin to make a circle continuing at the lope.
9. At centerline, change lead (simple or flying) and make a circle to the left.
10. Halt at cone A. Wait to be excused.

SENIOR * STOCK SEAT * GOLD

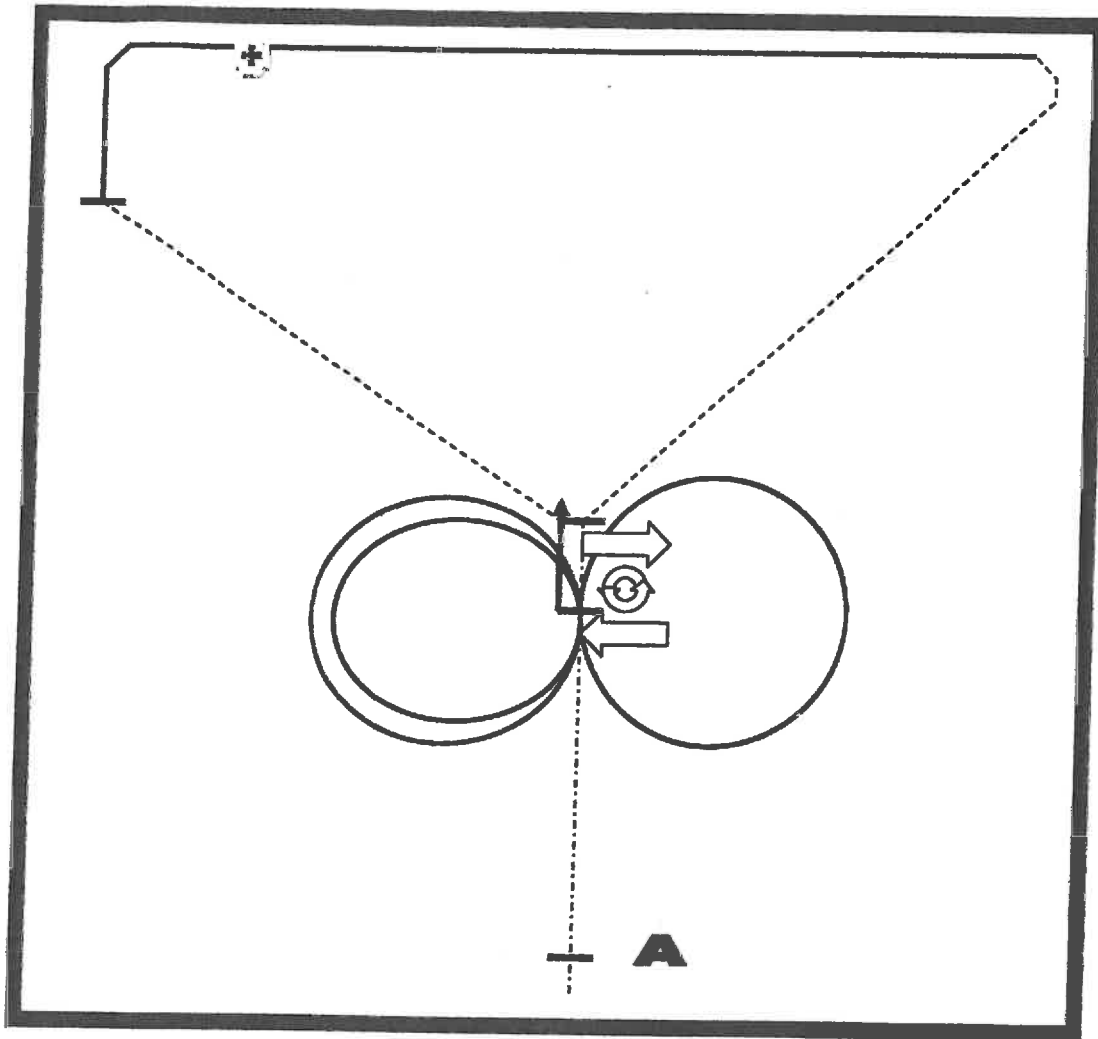

1. Wait at cone A. When acknowledged show an extended jog down the center of the arena. Halt at center.
2. Sidepass right 6 steps (3 crossovers).
3. Execute a 360-degree left haunch turn.
4. Sidepass left 6 steps (3 crossovers).
5. Drop stirrups and jog on a diagonal to the right, continuing to corner.
6. At corner, pick up a left lead and lope along the rail. Before corner, execute a flying lead change and continue lope around corner. Halt. Pick up stirrups.
7. Jog to center of arena and face cone A.
8. Lope $1\frac{1}{2}$ figure-8s starting to the right, showing two flying lead changes.
9. Halt at center. Stand for 8 seconds.
10. Back 5 steps and wait to be excused by the judge.