

Kinetics of salmon quality changes during thermal processing

Fanbin Kong^a, Juming Tang^{a,*}, Barbara Rasco^b, Chuck Crapo^c

^a Department of Biological Systems Engineering, Washington State University, Pullman, WA 99164-6120, United States

^b Department of Food Science and Human Nutrition, Washington State University, Pullman, WA 99164-6376, United States

^c Fishery Industrial Technology Center, University of Alaska Fairbanks, Kodiak, Alaska 99615-7401, United States

Received 2 November 2006; received in revised form 25 March 2007; accepted 1 April 2007

Available online 14 April 2007

Abstract

The kinetics of reactions leading to changes in salmon quality during thermal processing were evaluated. Small samples (D 30 mm × H 6 mm) cut from pink salmon (*Oncorhynchus gorbuscha*) fillets were sealed in aluminum containers (internal dimension: D 35 mm × H 6 mm) and heated in an oil bath at 100, 111.1, 121.1, and 131.1 °C for different time intervals up to 180, 150, 120, 90 min, respectively. A fractional conversion model was used to describe the increase in cook loss during heating; and a quadratic relationship to correlate cook loss with area shrinkage ratio. Color changes (CIE L^* , b^* and ΔE) involved whitening and browning phases. In the browning phase, the changes of CIE L^* , b^* and ΔE followed a zero-order reaction. The progressive change of texture with time as indicated by shear force during heating went through four different phases, and the second (rapid tenderizing) and third phases (slow toughening) were modeled using a first-order reaction kinetic model. The decay of thiamin during heating was modeled with two different relationships: a second-order reaction in which the temperature dependence of the rate constant followed an Arrhenius relationship; and a Weibull-log logistic model recently proposed.

© 2007 Elsevier Ltd. All rights reserved.

Keywords: Pink salmon; Food thermal process; Quality changes; Kinetics; Shear force; Cook loss; Area shrinkage; Color; Thiamin

1. Introduction

Salmon is one of the most important commercial fish species harvested in the United States. Thermal processing is commonly used in the fish industry to extend shelf life of salmon products. During thermal processing operations, salmon meat hermetically sealed in cans or pouches are processed in steam retorts at high temperatures (around 120 °C) for various periods from 20 to 90 min depending upon package size and shape. The high temperature heating may cause severe quality deterioration, such as degradation in color and texture, nutrient loss, cook loss (weight loss) and area shrinkage, rendering the products less attractive to most consumers. The most changes in salmon fillets during heating result from protein denaturation.

In particular, denaturation of heme proteins and oxidation of carotenoid pigments darken the products (Haard, 1992). The denaturation of the proteins also leads to reduced water holding capacity and shrunken muscle fibers, subsequently leading to a harder and more compact tissue texture (Harris & Shorthose, 1988). Our previous studies demonstrated that when heated at 121.1 °C, the salmon fillet texture profile during the course of heating had two-peaks, with the first peak in the 5 min and second peak at 1 hour heating time (Kong, Tang, Rasco, Crapo, & Smiley, 2007). These are likely the results of different reactions including toughening caused by denaturation of myofibrillar proteins and muscle dehydration, and tenderization by collagen solubilization. Heating causes progressive shrinkage and disintegration of the myofibril; and water, soluble proteins, and fats are expelled from the tissue (Leander, Hedrick, Brown, & White, 1980; Offer, Restall, & Trinick, 1984; Bertola, Bevilacqua, & Zartzyk, 1994). Heating also causes loss of nutrients such as thiamin.

* Corresponding author. Tel.: +1 509 335 2140; fax: +1 509 335 2722.
E-mail address: jtang@wsu.edu (J. Tang).

Nomenclature

t	time (min)	$b(T)$ and $n(T)$	temperature-dependent coefficients
C, C_0, C_t, C_∞	quality indicator value, quality indicator value at time zero and t , non-zero equilibrium value	L^*, a^*, b^*	color dimensions
T, T_{abs}	temperature ($^{\circ}\text{C}$), absolute temperature (K)	ΔE	color difference
f	quality index	TM, TM ₀ , TM _{t}	thiamin content ($\mu\text{g/g}$), thiamin content at time zero and time t
n	order of reaction	CL, CL _{t} , CL _{∞}	cook loss (%), cook loss at time t , equilibrium cook loss
k	reaction rate constant, $(\text{min})^{-n}$	AS, AS _{t} , AS _{∞}	area shrinkage ratio (%), area shrinkage ratio at time t , equilibrium area shrinkage ratio
k_0	frequency factor	MSE	mean square error
E_a	activation energy (J/mol)	CVS	computer vision system
R	gas constant (8.314 J/mol K)	MTB	multiple thin bladed Kramer type texture fixture
m and T_c	constants ($^{\circ}\text{C}^{-1}$, $^{\circ}\text{C}$)		

While traditional canning process is prevalent, new thermal processing technologies such as microwave sterilization processes have been investigated as a means of producing commercially sterile food with higher quality (Guan, Plotka, Clark, & Tang, 2002). Microwave processes involve volumetric heating that can sharply shorten heating times to reach a target temperature in pre-packaged foods (Guan et al., 2002). To develop new thermal processes and optimize existing retorting processes, knowledge of the kinetics associated with quality degradation is needed. Studies have been conducted on the kinetics of quality changes of food system during thermal processes. Zero-order and first-order kinetics are used to characterize the quality changes of muscle foods (Bhattacharya, Choudhury, & Studebaker, 1994; Bertola et al., 1994). But information on salmon quality changes during thermal processing and associated kinetics are limited.

The classic Arrhenius model is commonly used to describe rate–temperature relations in food and biological systems. It is particularly suitable for systems over a broad range of temperatures without a major change of mechanisms that determine kinetic rate constants. But there are situations where changes in system parameters are only noticeable above certain threshold temperatures. For these cases, Peleg, Engel, Gonzalez-Martinez, and Corradini (2002) proposed using a Weibullian-power law model, $C(t)/C_0 = \exp[-b(T)t^{n(T)}]$, to describe its temporal degradation, and using a log logistic equation, $b(T) = \log_e\{1 + \exp[k(T - T_c)]\}$, to describe the temperature dependence of the rate parameter. Oxidation reactions such as thiamin oxidation only occur at a noticeable rate above a certain temperature (Peleg et al., 2002). In this study, an attempt was made to use this method to explain thiamin degradation, and its performance was compared with classic reaction order – Arrhenius equation model.

The objectives of this study were to investigate the kinetics of salmon quality changes during high temperature thermal processes. Those quality indicators included cook

loss, area shrinkage, and deteriorations in color, texture and thiamin.

2. Materials and methods

2.1. Materials

Wild fresh whole grade A pink salmon (*Oncorhynchus gorbuscha*) were obtained from a seafood processing plant on Kodiak Island (Alaska) in August 2005, and immediately transported on ice to the Fisheries Industrial Technology Center (FITC) pilot plant. The fish weighed 1350 ± 100 g and were of similar size (370 ± 10 mm in length and 120 ± 10 mm in width). The fish were gutted, frozen and stored (-31 $^{\circ}\text{C}$) at the FITC pilot plant and shipped overnight to Washington State University, Pullman, WA.

2.2. Sampling and heating

To minimize the influence of slow heat transfer in the kinetics studies, small samples were used to reduce come-up time and improve heating uniformity. The sampling and heating of fish fillets followed methods previously described (Kong et al., 2007). Small disk shaped samples (6 mm in thickness and 30 mm in diameter) were taken using an electrical food slicer and a 30 mm diameter corer. Only the white muscle in the dorsal area were sampled in order to reduce the influence of heterogeneity of fish muscle on the cooking properties. The samples were hermetically sealed in custom-designed cylindrical aluminum test cells (Fig. 1) having a 35 mm inner dia, 6 mm inner height, and 2 mm wall thickness. The top and bottom lids of the cell included o-rings for a hermetic seal. The bottom lid allowed easy removal of fragile heated samples for texture and color measurements. Prior to sealing, a 0.1 mm diameter copper-constantan thermocouple (Type-T) was inserted through a rubber gland in the lid of the container

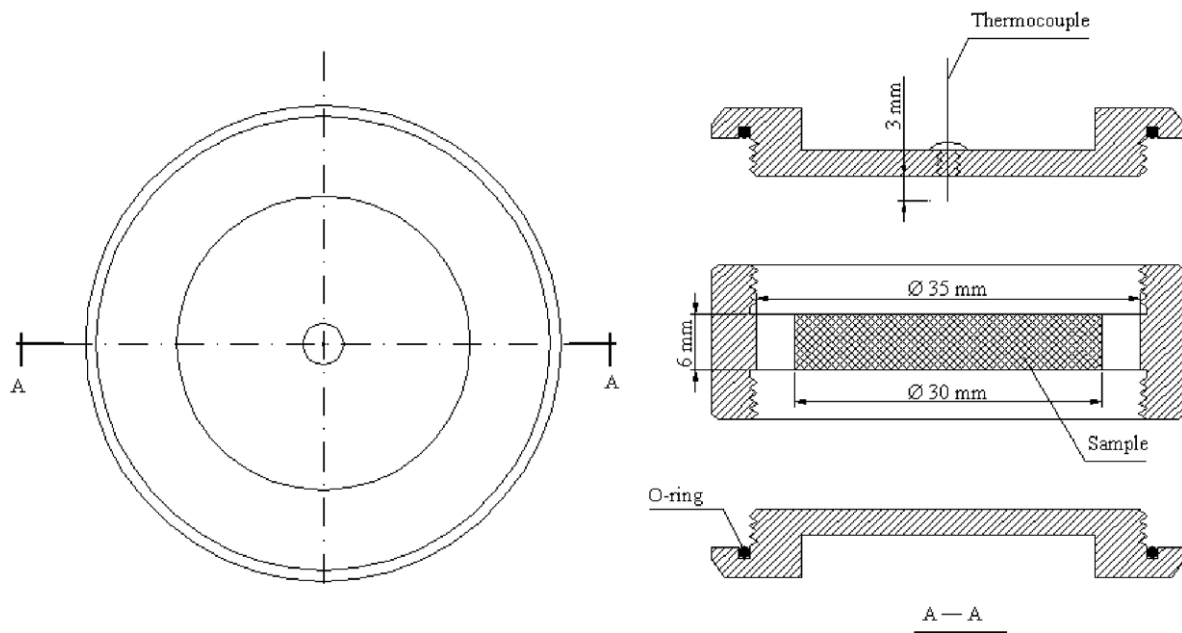

Fig. 1. Schematic diagram of WSU test cell.

to measure the temperature at the geometrical center of the sample. The immersion length (3 mm) of the probe in the sample was 30 times of the diameter, thus the influence of heat conduction along the thin wire probe to the sample temperature measurement was considered minimum. The thermocouple probe was calibrated in oil bath against pre-calibrated mercury-in-glass thermometer. It provided a measurement accuracy of $\pm 0.5\text{ }^{\circ}\text{C}$ in the tested temperature range and response time of 0.5 s in oil. The sealed cells were subjected to heat in an oil bath (Model HAAKE W13, Thermo Electron Corp., Germany) using glycerol as the heating medium. During heating, the signals from the thermocouple junctions were transferred to a computer equipped with a DLZe type data logger (DELTA-T Devices, Cambridge, England). The come-up time, i.e., the time for the sample center temperature to reach within $1\text{ }^{\circ}\text{C}$ of the total temperature rise, was on the order of 2.5–3 min. Sample cells were immediately placed in ice upon removal from the oil bath. The sample temperature dropped to below $20\text{ }^{\circ}\text{C}$ within 0.5 min, so the thermal effect of cooling step on the product quality was neglected. After cooling, the samples were dried with a filter paper, weighed in an analytical balance (Ohaus Analytical Plus, Pine Brook, NJ), and stored in a cooler ($4\text{ }^{\circ}\text{C}$) overnight for further analysis.

2.3. Experimental design

Sixteen fish were used, providing about 240 samples. Weighed amount of sodium chloride (1.5% w/w) was evenly distributed on the sample surface immediately before sealing and heating to simulate industrial canning practice of salmon. The experiments were conducted at four temperatures (100, 111.1, 121.1, $131.1\text{ }^{\circ}\text{C}$). Table 1 shows the temperature and time conditions employed. Six replicates were used for each temperature and time combination.

2.4. Cook loss

The weight of raw and heated samples was recorded to calculate cook loss. Percentage of cooking loss was calculated as:

$$\text{Cook loss} = \frac{\text{weight of raw sample} - \text{weight of cooked sample}}{\text{weight of raw sample}} \times 100\% \quad (1)$$

2.5. Texture

A multiple thin bladed Kramer type texture fixture (MTB) developed by Kong et al. (2007) was used to measure shear force of the samples. The MTB consisted of upper part and lower part: the upper part had 10 thin blades, and the lower part was a support base with slots. It used 0.5 mm-thick blades with 40 mm blade length and 50 mm width. The probe was fitted to a Texture Analyser TA-XT2 (Stable Micro Systems Ltd., Surrey, UK) equipped with a 5 kg load cell. Before measurement, the

Table 1
Experimental conditions

Temperature ($^{\circ}\text{C}$)	Heating time (min)								
100	0	3	10	20	30	60	90	120	180
111.1	0	2.75	5	10	20	30	60	90	150
121.1	0	2.5	5	10	15	20	30	60	120
131.1	0	2.5	5	10	15	20	30	60	90

raw and heated samples were allowed to equilibrate to room temperature (approximately 22 °C), which took approximately half an hour. The samples were carefully placed on the support base so that the blades were perpendicular to muscle fibers. The traveling speed for the upper blades was set at 1 mm/s. The force–time graphs were recorded by a computer and analyzed using the Texture Expert for Windows (version 1.15, Stable Micro Systems Ltd.). The shear force was measured as the peak height in the force–time profile.

2.6. Color and area measurement

A computer vision system (CVS) described by Kong et al. (2007) was used to capture color images of fresh and cooked samples for color and area measurements. Color images were downloaded into the computer for analysis. The color parameters (CIE L^* , a^* and b^*) were derived using Adobe Photoshop CS2 software (Version 8.0). For sample area determination, the Vision IMAQ Builder image processing software Version 6.1 (National Instruments, Austin, TX) was used. The area of sample image was determined using the “area measurement” menu. The shrinkage ratio was calculated as:

Area shrinkage ratio

$$= \frac{\text{area of raw sample} - \text{area of cooked sample}}{\text{area of raw sample}} \times 100\% \quad (2)$$

2.7. Chemical analysis

Samples subjected to a specific temperature and time combination were homogenized in a blender. Moisture content was determined by vacuum drying a sample (3–5 g) at 65 °C to constant weight (Hart & Fisher, 1971). Lipid content was determined using modified Folch method (Folch, Lees, & Sloan Stanley, 1957; Iverson, Lang, & Cooper, 2001). Thiamin content in the raw and heated samples was determined using the Thiochrome method (AOAC 942.23, 2000), and the fluorescent intensity of thiochrome extracted with isobutanol was determined in a fluorometer (Model FluoroMax-3, Jobin Yvon Inc., Edison, NJ) at an excitation wavelength of 365 nm and an emission wavelength of 435 nm.

2.8. Data analysis

Generally, changes in quality factor “ C ” under isothermal conditions can be represented by (Wang, Lau, Tang, & Mao (2004)):

$$\frac{dC}{dt} = -k(C)^n \quad (3)$$

where k is the rate constant, C is the quantitative indicator of a quality attribute at time t , and n is the order of reac-

tion. The integrated form for zero-, first- and second-order kinetic models is listed in Eqs. (4)–(6), respectively.

$$\text{zero-order} : C_t = C_0 - k \cdot t \quad (4)$$

$$\text{first-order} : \ln \frac{C_t}{C_0} = -k \cdot t \quad (5)$$

$$\text{second-order} : kt = \frac{1}{C_t} - \frac{1}{C_0} \quad (6)$$

where C_0 represents the initial value at time zero, C_t is the value at time t , k is the rate constant. Fractional conversion model (a modified first-order kinetic model) has also been vastly used, in which a quality index, f , is used to express the extent of quality change at any time t :

$$f = \frac{C_0 - C_t}{C_0 - C_\infty}$$

For a first-order reaction, the logarithm of $(1 - f)$ plotted against time is linear. The model becomes:

$$\ln(1 - f) = \ln \left(\frac{C_t - C_\infty}{C_0 - C_\infty} \right) = -k \cdot t \quad (7)$$

where C_∞ is the non-zero equilibrium quality property after prolonged heating time.

The Arrhenius equation is usually applied to describe the reaction rate constant temperature dependence:

$$k = k_0 \cdot e^{-\frac{E_a}{RT_{\text{abs}}}} \quad (8)$$

If Eq. (8) indeed applies to a reaction in consideration, a plot of the rate constant on semi-logarithmic scale as a function of reciprocal absolute temperature ($1/T_{\text{abs}}$) should give a straight line, and the activation energy can be determined as the slope of the line multiplied by the gas constant R .

Peleg et al. (2002) proposed using Weibullian-power law model to describe isothermal degradation of food quality:

$$C(t)/C_0 = \exp[-b(T)t^{n(T)}] \quad (9)$$

where $b(T)$ and $n(T)$ are temperature-dependent coefficients. $b(T)$ can be described by an empirical model (Peleg et al., 2002):

$$b(T) = \log_e \{1 + \exp[m(T - T_c)]\} \quad (10)$$

where T is temperature (°C), m and T_c are constants. The solver command in Microsoft Excel 2002 was used to derive optimal $b(T)$, $n(T)$, m and T_c to produce the lowest mean square error between predicted and observed values.

In our analysis on kinetics data, unless otherwise stated, the samples taken at the end of come-up times (2.5–3 min) were used as the zero-time samples. This was the time when the sample center reached within 1 °C from the set temperature. The quality values of zero-time samples were used as the initial values. The moisture, lipid and thiamin contents were determined in duplicate. All the quality data were analyzed by using the analysis of variance (ANOVA) in the general linear models procedure of the SAS System for Windows V8.01 (SAS User’s Guide, 1996). Differences

between group means were analyzed by Duncan's multiple-range test. Statistical significance was set at a 0.05 probability level.

3. Results and discussion

3.1. Effects of cook loss and area shrinkage

Cook loss increased significantly with increasing temperature and heating time (Fig. 2). Although consistently increased with heating time, most of the cook loss occurred within the first 30 min. The first portion of the curves had steeper slopes. As the heating progressed, the slope gradually leveled off and the cook losses reached an equilibrium, which was 13.2%, 15.4%, 18.5% and 20.2% for 100, 111.1, 121.1 and 131.1 °C, respectively. The changes of equilibrium cook loss CL_{∞} with heating temperature followed the relationship below:

$$CL_{\infty} = 0.2332T - 10.18 \quad R^2 = 0.988 \quad (11)$$

Fig. 2 shows a considerable cook loss (>40% of the total loss occurred within the entire heating period) occurred during the first 2.5–3 min of heating that was within the non-isothermal stage. In kinetic modeling, the data for this period were combined to make models more widely applicable. The increase of cook loss with time was fitted to a fractional conversion model (Eq. (7)). The temperature dependence of the rate constant was expressed by the Arrhenius equation (Eq. (8)). The rate constants corresponding to the four temperatures, E_a and k_0 values, and coefficient of correlation are shown in Table 2. The activation energy of 36.98 kJ/mol is in the same range of beef that was reported to be 54.93 kJ/mol (Bertola et al., 1994). The frequency factor k_0 is 5761.2/min. After incorporating the above values, the equation becomes:

$$k = 5761.2 \times e^{-\frac{36.98 \times 1000}{8.314 \times (273+T)}} \quad (12)$$

Cook loss can then be estimated using Eq. (13) converted from Eq. (7):

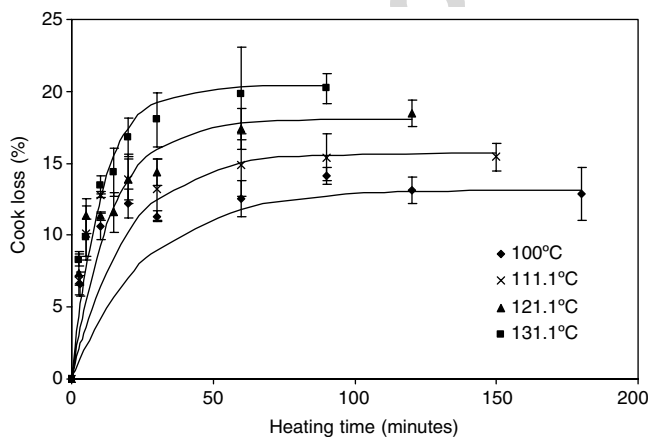

Fig. 2. The change of cook loss of salmon fillet at different heating temperatures fitted with a fractional conversion model. Bars indicate the standard deviation from six determinations.

Table 2

First-order kinetic parameters for cook loss of salmon fillets after heat treatments at four temperatures

T (°C)	k (min^{-1}) $\times 10^{-3}$	R^2	E_a (kJ/mol)	k_0 (min^{-1})	R^2
100	36.0	0.891	36.98	5761.2	0.955
111.1	54.2	0.962			
121.1	79.6	0.931			
131.1	87.7	0.956			

$$CL_t = (1 - e^{-kt}) \cdot CL_{\infty} \quad (13)$$

where CL_{∞} took the values obtained from Eq. (11). This model gives a good fit to the cook loss data when samples were heated at 121 and 131 °C. It also fit well with the data of 100 and 111.1 °C after 30 min heating. Considering the heating time used in industrial canning practices for salmon is much longer (60 min at 111.1 °C and 773 min at 100 °C to achieve an equivalent lethality value (F_0) of 6), this model still has practical usefulness (see Fig. 2).

Most of the cook loss is water (>85%), others are lipids and solids that includes collagen or gelatin, muscle fragments and coagulated sarcoplasmic proteins. Thermal denaturation of muscle proteins is the primary mechanism leading to the moisture loss (Bell, Farkas, Hale, & Lanier, 2001). Most water in muscle is located within the myofibrils, in the narrow channels between thick and thin filaments (Offer et al., 1984; Bertola et al., 1994). Heating caused denaturation of myosin and shrinkage of myofibrils, and a subsequent expulsion of water (Ofstad, Kidman, Myklebust, & Hermansson, 1993). Heating caused moisture to decrease from the original level of 75.3% to 69.2–70.4% (wet basis) in the tested samples, and higher temperature treatment resulted in lower moisture products. Similar to cook loss, significant reduction in sample moisture ($P < 0.05$) occurred in the first 30 min. After that, the moisture gradually reached equilibrium. The lipid recovered in the heated samples increased slightly from 1.46% to 1.55–1.71% (wet basis) indicative of a relatively higher loss of moisture from these samples compared to lipid. Similar observations were reported by Al-Saghir et al. (2004).

Protein denaturation reduces the dimension of myofibrils and collagen, resulting in shrinkage of muscle fiber diameter and sarcomere length (Palka & Daun, 1999; Bell et al., 2001). Similar to cook loss, area shrinkage in salmon fillets increased sharply in the initial heating period and then gradually approached a relatively constant value (plateau) as the heating progressed beyond 30 min. The height of the plateau was positively correlated to heating temperature. For example, the largest shrinkage ratio measured for 100, 111.1, 121.1, and 131.1 °C was 10.34%, 15.6%, 20.1%, 24.4%, respectively. The plateau AS_{∞} (%) values were linearly related to temperature T (°C) as:

$$AS_{\infty} = 0.4523 \cdot T - 34.56 \quad R^2 = 0.999 \quad (14)$$

A quadratic equation was used to relate area shrinkage ratio and cook loss as following:

$$AS = 0.0781 \cdot CL^2 - 1.0587 \cdot CL + 12.458 \quad R^2 = 0.915 \quad (15)$$

where $CL = 6.6\text{--}20.2\%$. The non-linear relationship between the cook loss and area shrinkage ratio could be explained by the fact that cook loss is a result of heat-induced volume change that is a function of both area and thickness reduction. Positive correlations between sarcomere shrinkage and cook loss have been documented in beef (Palka & Daun, 1999), pork (Barbera & Tassone, 2006) and fish muscle (Ofstad, Kidman, & Hermansson, 1996).

Degrees of shrinkage and cook loss vary between the fish groups. Salmon muscle is more heat-stable than cod muscle, which likely results from the different collagen content (Ofstad et al., 1993). Cook loss and area change are also significantly affected by sample size and shape (Laroche, 1980). Therefore, the Eqs. (11)–(15) provide a rough approximation. Modifications are needed to determine the real effects of cook loss and area change for retorted product using industrial practices.

3.2. Effect of color

Fig. 3 shows the change of CIE L^* , a^* , b^* with heating time. During the heating, the muscle color underwent a two-phase change: a rapid whitening phase followed by a slow browning phase. The whitening phase occurred within the first 10 min: the pink color of fish muscle quickly faded to whitish, with the L^* increased to a maximum (Fig. 3a), and a^* and b^* decreased to a minimum ($P < 0.05$, Fig. 3b and c) at all tested temperatures. The rapid whitening resulted from the quick denaturation of heme proteins (hemoglobin and myoglobin) and oxidation of carotenoids (Haard, 1992). Franklin, Crockford, Johnston, and Kamunde (1994) reported that roughly 50% of the haemoglobin in rockcod was denatured after 19 min at 50 °C. The whitening phase is concomitant with the formation of the cooked meat haemoprotein. The rate of cooked meat haemoprotein formation (measured as the rate of loss of myoglobin solubility) was found to obey a first-order kinetic in beef and lamb (Geileskey, King, Corte, Pinto, & Ledward, 1998). Fish haemoglobins are considerably less stable than mammalian haemoglobins (Franklin et al., 1994).

In the browning phase, Maillard reaction between sugars, fish proteins or amines as well as protein–lipid reaction dominated (Haard, 1992). As the processing temperature and time increased, more browning products were produced (Whistler & Daniel, 1985), which is reflected by the decreased L^* value (Fig. 3a) and the increased b^* values (Fig. 3c). The L^* , b^* of the tissue were significantly affected by both processing temperature and time ($P < 0.05$); and higher temperature resulted in greater rates of decrease in those values. However, a^* generally did not show significant changes ($P > 0.05$, Fig. 3b). To describe the total color changes of the salmon fillets in the browning phase, color

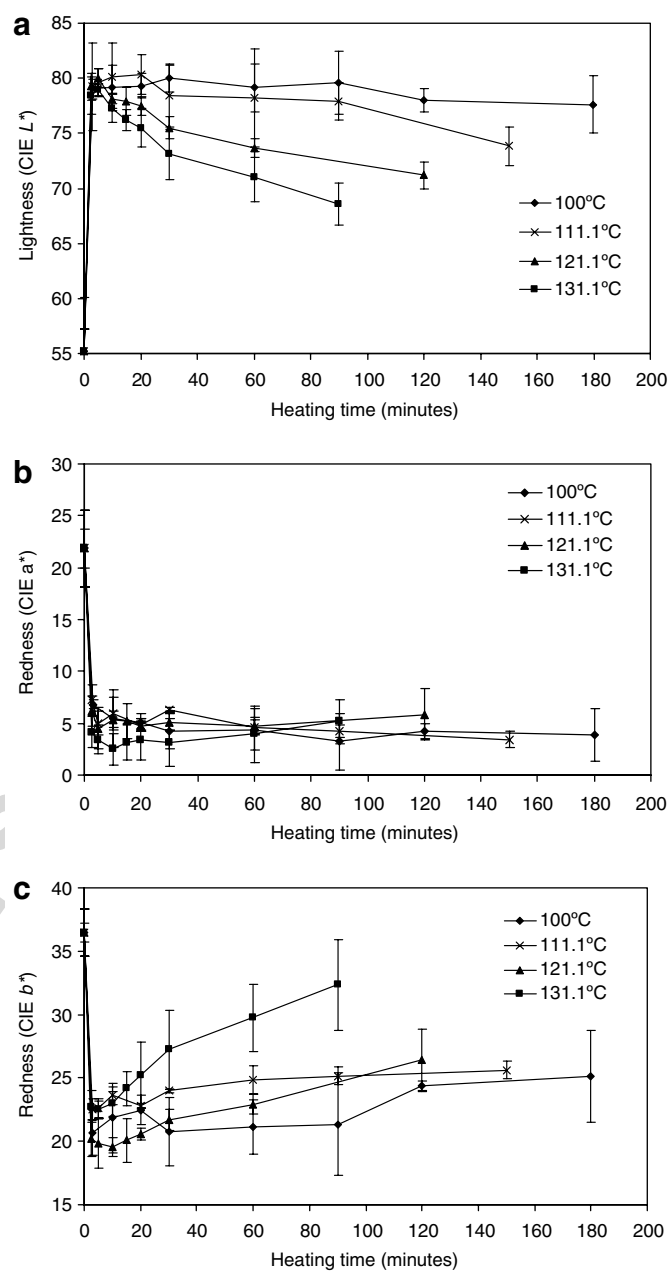

Fig. 3. The change in the color of salmon fillet at different heating temperatures: (a) CIE L^* , (b) CIE a^* , (c) CIE b^* . Bars indicate the standard deviation from six determinations.

difference (ΔE) was calculated using Eq. (16) (Feng & Tang, 1998):

$$\Delta E = \sqrt{(L^* - L_0^*)^2 + (a^* - a_0^*)^2 + (b^* - b_0^*)^2} \quad (16)$$

where L_0^* , a_0^* and b_0^* were for the samples taken after 10 min heating, representing initial color values in the browning phase. The kinetics of changes of L^* , b^* and ΔE in the browning phase were analyzed. The samples taken at 10 min heating time, when the browning phase started, were used as time zero samples. Over the tested temperature range, the experimental data of L^* , b^* and ΔE were best fitted to a zero-order reaction. Arrhenius equation was used to express the temperature dependence of the rate

constants and calculate E_a values for L^* , b^* and ΔE . The results are summarized in Table 3. The E_a values fall into a range of 70–100 kJ/mol, which is within the range cited in the literatures for quality changes (60–120 kJ/mol) (Lund, 1977) and for brown chemical marker formation in foods (Lau et al., 2003; Wang et al., 2004; Pandit, Tang, Mikhaylenko, & Liu, 2006). Deterioration of color is af-

ected by composition such as sugar and amino acid content, total solid content, pH, acidity and also the temperature range of the study (Haard, 1992; Hui et al., 2006). Fig. 3 also indicates that shorter time heating process, such as microwave sterilization process that uses ~10–20 min heating time at 121.1 °C, might result in lighter and more fresh-like products.

Table 3
Zero-order kinetic parameters for color changes of salmon fillets during heat treatments at four temperatures

Color index	Temperature (°C)	k (min^{-1}) $\times 10^{-3}$	R^2	E_a (kJ/mol)	k_0 (min^{-1})	R^2
CIE L^*	100	0.204	0.669	87.99	7.64×10^8	0.949
	111.1	0.765	0.905			
	121.1	1.242	0.936			
	131.1	1.889	0.952			
CIE b^*	100	0.136	0.605	73.76	1.49×10^6	0.812
	111.1	0.114	0.788			
	121.1	0.383	0.985			
	131.1	0.715	0.961			
ΔE	100	0.458	0.587	99.46	4.49×10^{10}	0.977
	111.1	1.645	0.887			
	121.1	3.098	0.963			
	131.1	5.575	0.975			

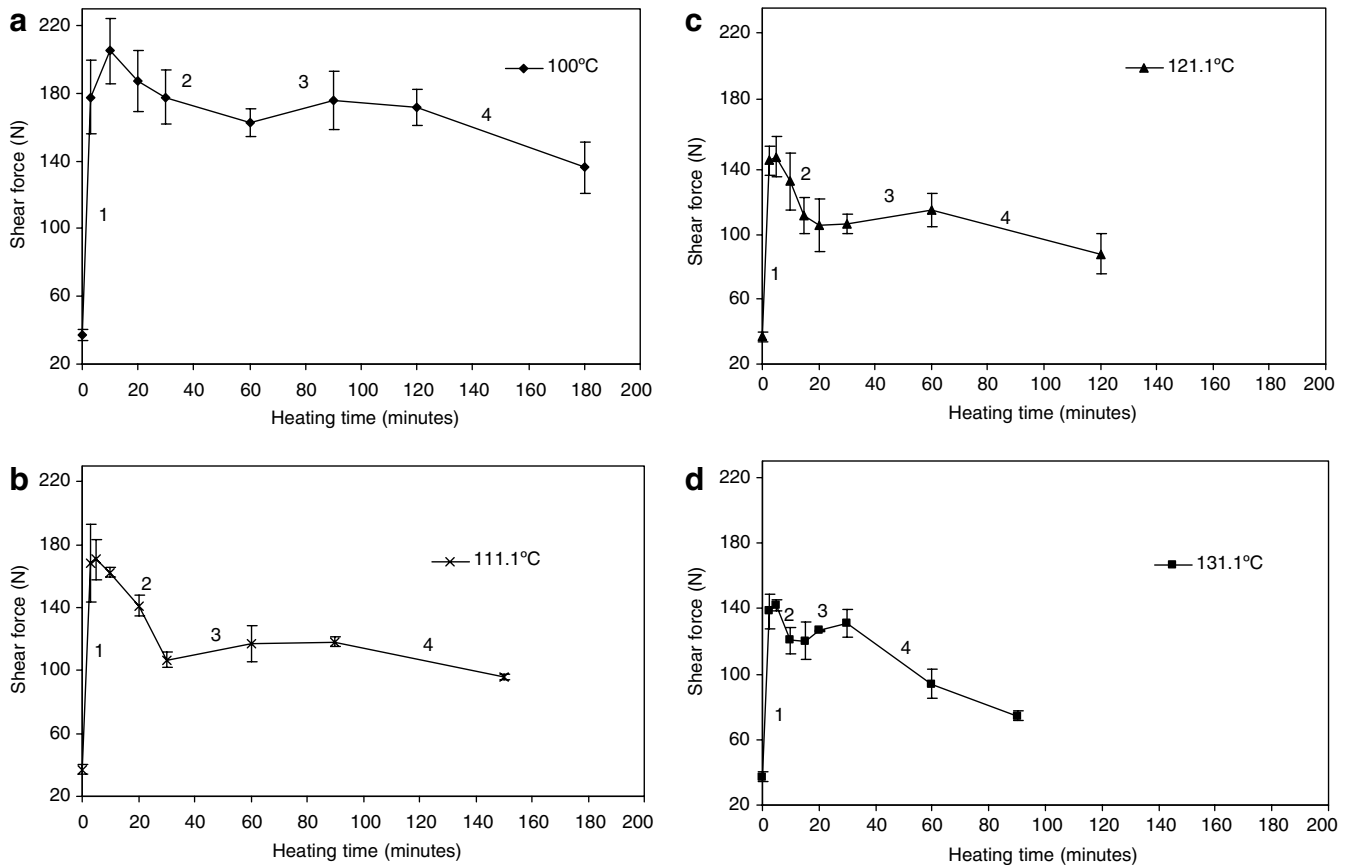

Fig. 4. The change of shear force of salmon fillet at different heating temperatures: (a) 100 °C, (b) 111.1 °C, (c) 121.1 °C, (d) 131.1 °C. The number 1, 2, 3, 4 indicate different phases. Bars indicate the standard deviation from six determinations.

3.3. Effect of shear force

Fig. 4 shows the shear force changes with time at the four tested temperatures. The changes in shear force with heating time exhibited two peaks at the four temperatures, dividing the profile into four phases: (1) rapid toughening, the shear force increased from raw muscle to the first peak; (2) rapid tenderization, the shear force decreased from the first peak to a minimum; (3) slow toughening, the shear force increased again to a second peak; and (4) slow tenderization, the tissue gradually became soft as heating time prolonged. The two peaks in the shear force of heated salmon indicate that the long time heating frequently used in the traditional canning processes (e.g. mostly ~50–90 min depending on packaging size and shape) may negatively affect the tenderness of salmon meat. The optimum heating time from the texture viewpoint should be between the first and the second peaks. The four-phase shear force changes could be explained by the net effect of different reactions (Kong et al., 2007). Thermal denaturation temperatures of fish muscle proteins were observed between 40 and 80 °C (Bell et al., 2001; Ofstad et al., 1996). At the high temperatures used in this study, both the tissue-toughening caused by denaturation of myofibrillar proteins and tissue-softening caused by collagen gelation and solubilization might have been contributed to the observed changes in salmon fillet texture. As heating prolonged, the prevalent reactions shifted, resulting in a fluctuation in shear force of the muscle. Fig. 4 also indicates that higher temperature expedited the texture changes. Shorter time was needed to complete the four phases when heated at higher temperatures: the rapid toughening phase lasted 10 min at 100 °C, and 5 min at 111.1, 121.1 and 131.1 °C; the rapid tenderizing phase lasted at 50, 25, 15 and 10 min at 100, 111.1, 121.1 and 131.1 °C, respectively. The slow toughening phase lasted 60 min at 100 and 111.1 °C, 40 min at 121.1 °C and 15 min at 131.1 °C. Higher temperature induced faster denaturation of proteins, and subsequently more rapid textural changes. Protein denaturation rate increases about 600-fold for every 10 °C in temperatures (Anglemier & Montgomery, 1976).

Fig. 4 shows that the shear force decreased as the temperature increased from 100 to 131.1 °C. For example, the maximum shear force (corresponding to the first peak) was 205, 170, 148 and 142 N for 100, 111.1, 121.1 and 131.1 °C, respectively. This phenomenon is opposite to the observed texture changes in Pacific chum salmon when

heated at temperatures less than 100 °C (Bhattacharya, Choudhury, & Studebaker, 1993). These authors studied the effect of hydrothermal processing on the texture of Pacific chum salmon at 60–100 °C, and found that the hardness increased as the heating temperature increased. This discrepancy with our findings might be due to the coexistence and counteraction of the hardening and softening reactions at high temperatures. Also, higher temperature promoted a rapid disintegration and fragmentation of the fish muscle, contributing to the decrease in the measured shear force. This effect can be also seen by an increase in the minimum shear force at higher temperatures: 120 N for the 131 °C, and 105 N for the 111.1 and 121.1 °C.

The kinetics of the rapid tenderization and the slow toughening phases were evaluated. For the former phase, the shear force versus time curves at 100, 111.1 and 121.1 °C were used. The zones analyzed were from 10 to 60 min at 100 °C, 5 to 30 min at 111.1 °C, and 5 min to 20 min at 121.1 °C. For the latter phase, the shear force versus time curves at 111.1, 121.1 and 131.1 °C were used. The zones analyzed were from 15 to 30 min at 131.1 °C, 20 to 60 min at 121.1 °C, 30 to 90 min at 111.1 °C. First-order kinetic model was used to fit the experimental curves, and an Arrhenius model was used to express the temperature dependence of rate constants. The resultant rate constants, activation energy and correlation coefficient are shown in Table 4. The E_a for the two phases are 100.47 and 70.04 kJ/mol, respectively, much lower than reported activation energies of protein denaturation (200–600 kJ/mol) (Anglemier & Montgomery, 1976; Bertola et al., 1994). Therefore, protein denaturation should not be the contributing factor for the texture changes in these two phases: in the high temperatures used in this study, most proteins should have been denatured in the first phase. The dominant contributing factors might include dehydration, aggregation, and disintegration. Employing differential scanning calorimetry (DSC) analysis, and microscopic examination of collagen and muscle fibers might help reveal the mechanisms involved in the nature of these protein changes that occur during these four phases.

3.4. Effect of thiamin retention

Salmon is an important thiamin source in human diet. Apart from the nutritional significance, thiamin content is commonly used as an index of quality of canned low acid foods. Thiamin is one of the least thermostable water soluble

Table 4
First-order kinetic parameters for shear force changes of salmon fillets after heat treatments at four temperatures

Texture phase	T (°C)	k (min ⁻¹) × 10 ⁻³	R^2	E_a (kJ/mol)	k_0 (min ⁻¹)	R^2
Second phase (rapid tenderization)	100	4.34	0.926	100.47	6.00×10^{14}	0.949
	111.1	18.53	0.957			
	121.1	23.89	0.966			
Third phase (slow toughening)	111.1	1.66	0.817	76.04	3.33×10^{10}	0.931
	121.1	2.31	0.976			
	131.1	5.42	0.921			

Table 5
Second-order kinetic parameters for thiamin retention of salmon fillets after heat treatments at four temperatures

T (°C)	k (min ⁻¹) × 10 ³	R^2	E_a (kJ/mol)	k_0 (min ⁻¹)	R^2
100	5.9	0.966	105.23	3.47×10^{12}	0.990
111.1	17.9	0.974			
121.1	44.4	0.995			
131.1	77.5	0.989			

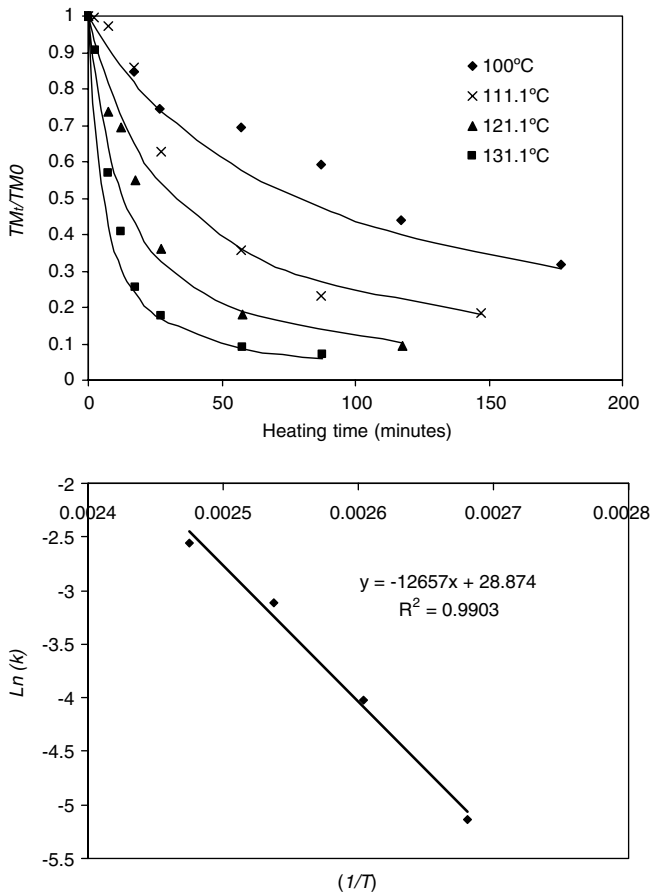

Fig. 5. Top: The change of thiamin content of salmon fillet at different heating temperatures fitted with a second-order model. Bottom: Arrhenius plot showing the temperature dependence of rate constants.

vitamins. The measured thiamin content in the raw salmon (TM_0) was 2.03 $\mu\text{g/g}$ tissue, which is in agreement with literature values ranging between 2 and 3 $\mu\text{g/g}$ tissue (Hui et al., 2006). After heating, it was reduced to 0.64, 0.34, 0.18, and 0.15 $\mu\text{g/g}$ at the end of longest tests at 100, 111.1, 121.1 and 131.1 °C. The rate of thiamin losses increased with an increase in temperature. Heat treatment caused thiamin oxi-

dation and leaching of this water soluble vitamin into expressed fluid. The thiamin retention data was best fitted to a second-order reaction, and the temperature dependence of the rate constant was expressed by the Arrhenius equation. Table 5 shows these kinetic parameters. The high correlation coefficients ($R^2 > 0.96$) suggest that this model is satisfactory for describing the thiamin degradation in salmon products. The E_a and k_0 values are 105.2 kJ/mol (z -value of 27.4 °C) and $3.47 \times 10^{12}/\text{min}$. Although most previous study shows a first-order kinetic for vitamin degradation (Taoukis, Labuza, & Saguy, 1997), second-order kinetics have also been reported (Viberg, Ekstrom, Fredlund, Oste, & Sjöholm, 1997; Kessler & Fink, 1986). Kessler and Fink (1986) explained the thermal decomposition of thiamin in cow's milk with a second-order reaction kinetics, and found the E_a and k_0 values to be 100.8 kJ/mol and $5.14 \times 10^{11}/\text{min}$, respectively, quite close to the present results. Based on the kinetic parameters and Eqs. (6) and (8), Eqs. (17) and (18) were proposed to estimate rate constant k and thiamin retention (TM_t/TM_0) at a specific heating temperature T for a given time t . Fig. 5 shows the experimental data of thiamin retention fitted with model curves, and the Arrhenius plot. A good fit can be seen.

$$k = 3.47 \times 10^{12} \times e^{-\frac{105.23 \times 1000}{8.314 \times (273+T)}} \quad (17)$$

$$\frac{TM_t}{TM_0} = \frac{1}{k \cdot TM_0 \cdot t + 1} \quad (18)$$

3.5. Using a weibull-log logistic model to model thiamin retention

The thiamin degradation data were fitted to Eqs. (9) and (10). At first, optimal $n(T)$ and $b(T)$ values corresponding to each temperature in Eq. (9) were derived using the Solver command in EXCEL software, and the four resultant n values were in a narrow range between 0.92 to 1.01, with mean square error (MSE) in a order of 10^{-3} (Table 6). The MSE were comparable to literature values (Corradini & Peleg, 2004, 2006). When a fixed n value (1.00) was used for all temperatures, the corresponding MSE were very close to those for variable $n(T)$, indicating a possibility to further simplify the model. The normalized degradation curves and the fit of Eq. (9) using fixed power $n(T)$ (1.00) are shown in Fig. 6, also included is the fit of the temperature dependence of $b(T)$ with the log logistic model. A good fit of the model can be observed, demonstrating that the Weibull-log logistic model was an adequate model for quantifying the isothermal decay pattern of thiamin in sal-

Table 6
Degradation parameters calculated with the Weibull-log logistic model

Temperature (°C)	$n(T)$	MSE × 10 ⁻³ (R^2)	n	$b(T)$ (min ⁻ⁿ) × 10 ⁻³	MSE × 10 ⁻³ (R^2)	m (°C ⁻¹)	T_c (°C)	MSE 10 ⁻⁸ (R^2)
100	0.92	2.14 (0.963)	1.00	6.66	2.30 (0.960)	0.078	165	2.2 (1.000)
111.1	1.10	3.06 (0.974)	1.00	14.95	3.27 (0.973)			
121.1	0.97	2.55 (0.978)	1.00	32.57	2.56 (0.978)			
131.1	1.01	2.15 (0.986)	1.00	69.54	2.16 (0.986)			

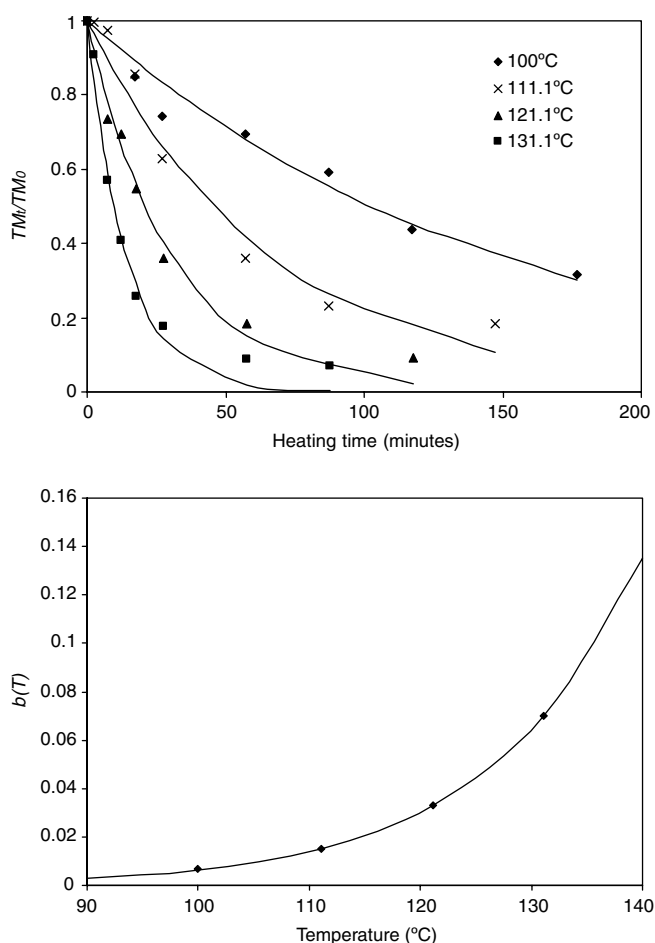

Fig. 6. Top: The change of thiamin content of salmon fillet at different heating temperatures fitted with the Weibullian model. Bottom: The temperature dependence of $b(T)$ fitted with the log logistic model.

mon fillets. The value of $n(T)$ is basically 1, indicating a first-order kinetics. However, a second-order model was shown to best fit the thiamin data. Further studies are needed to explain the reasons for the discrepancy between the two models.

Table 6 shows the degradation parameters using Eqs. (9) and (10) as models. The m and T_c values are $0.078\text{ }^{\circ}\text{C}^{-1}$ and $165\text{ }^{\circ}\text{C}$, respectively. The obtained parameters for the Weibull-log logistic model agree with reported studies on thiamin loss for other foods. Corradini and Peleg (2006) reported $n(T)$, m , and T_c of $0.83\text{--}1.05$, $0.041\text{--}0.056\text{ }^{\circ}\text{C}^{-1}$ and $176\text{--}190\text{ }^{\circ}\text{C}$, respectively, depending upon pH values, for thiamin degradation in red gram splits (*Cajanus cajan* L.), an important grain legume and a rich source of thiamin in India, during heating at temperatures between 50 and $120\text{ }^{\circ}\text{C}$. According to Peleg et al. (2002), T_c could be related to the minimum temperature ($^{\circ}\text{C}$) above which thermal degradation starts to accelerate, and m to the steepness of the rate-temperature relationship beyond T_c . Therefore, the higher m value and lower T_c in our study might indicate the thiamin in salmon fillets is more susceptible to thermal processing than in red gram splits.

4. Conclusions

The increase in cook loss of salmon fillet during high temperature heating followed a first-order reaction, with the greatest amount of cook loss occurring within the first 30 min. High temperature caused the salmon muscle color to whiten in the first 10 min followed by browning as heating progressed, and the color changes in the browning phase can be fitted to a zero-order reaction. Short time heating such as microwave sterilization processes might greatly reduce cook loss and area shrinkage, increase thiamin retention, and favor a lighter color in the salmon products. There were four phases to the change in shear force observed as samples were heated at all the test temperatures, with the second and third phases exhibiting first-order kinetics. The two peak phenomenon in the shear force changes of heated salmon indicates that long time heating may not necessarily lead to tender texture. However, further study is needed to fully understand the mechanisms involved. The degradation of thiamin in heated salmon fillets was second-order, with an E_a of 105.2 kJ/mol . Weibullian-power law and log logistic model provided adequate description of thiamin degradation data and the temperature dependence of $b(T)$, and the m and T_c values were $0.078\text{ }^{\circ}\text{C}^{-1}$ and $165\text{ }^{\circ}\text{C}$, respectively. The models presented in this study can be combined with microbial inactivation kinetic to develop optimum process parameters, including heating time and temperature, to produce high quality shelf-stable salmon products.

Acknowledgments

The authors thank Ocean Beauty Seafoods, Inc. (Seattle, WA) for providing fish samples. The grant support is from USDA CSREES Grant (2004-34422-15179) through the University of Alaska Fairbanks Subcontract Number 05-0087.

References

- Al-Saghir, S., Thurner, K., Wagner, K. H., Frisch, G., Luf, W., Razzazi-Fazeli, E., et al. (2004). Effects of different cooking procedures on lipid quality and cholesterol oxidation of farmed salmon fish (*Salmo salar*). *Journal of Agricultural and Food Chemistry*, *52*, 5290–5296.
- Anglemier, A. F., & Montgomery, M. W. (1976). Amino acids, peptides, and proteins. In O. R. Fennema (Ed.), *Food chemistry* (pp. 205–278). Marcel Dekker.
- AOAC International (2000). *Official methods of analysis of AOAC International* (17th ed.). Gaithersburg, MD, USA: Association of Analytical Communities.
- Bell, J. W., Farkas, B. E., Hale, S. A., & Lanier, T. C. (2001). Effect of thermal treatment on moisture transport during steam cooking of Skipjack Tuna (*Katsuwonus pelamis*). *Journal of Food Science*, *66*(2), 307–313.
- Barbera, S., & Tassone, S. (2006). Meat cooking shrinkage: Measurement of a new meat quality parameter. *Meat Science*, *73*(3), 467–474.
- Bertola, N. C., Bevilacqua, A. E., & Zritzky, N. E. (1994). Heat treatment effect on texture changes and thermal denaturation of proteins in beef muscle. *Journal of Food Processing and Preservation*, *18*(1), 31–46.

- Bhattacharya, S., Choudhury, G. S., & Studebaker, S. (1993). Hydrothermal processing of Pacific chum salmon: Effects on texture and in-vitro digestibility. *Journal of Food Quality*, 16(4), 243–251.
- Bhattacharya, S., Choudhury, G. S., & Studebaker, S. (1994). Color changes during thermal processing of Pacific chum salmon. *Journal of Aquatic Food Product Technology*, 3(1), 39–48.
- Corradini, M. G., & Peleg, M. (2004). A model of non-isothermal degradation of nutrients, pigments and enzymes. *Journal of the Science of Food and Agriculture*, 84, 217–226.
- Corradini, M. G., & Peleg, M. (2006). Prediction of vitamins loss during non-isothermal heat processes and storage with non-linear kinetic models. *Trends in Food Science & Technology*, 17(1), 24–34.
- Feng, H., & Tang, J. (1998). Microwave finish drying of diced apples in spouted bed. *Journal of Food Science*, 63(4), 679–683.
- Folch, J., Lees, M., & Sloan Stanley, G. H. (1957). A simple method for the isolation and purification of total lipids from animal tissues. *Journal of Biological Chemistry*, 226, 497–509.
- Franklin, C. E., Crockford, T., Johnston, I. A., & Kamunde, C. (1994). The thermostability of haemoglobins from the hot-spring fish, *Oreochromis Alcalicus Grahami*: Comparisons with antarctic and temperate species. *Journal of Thermal Biology*, 19(4), 277–280.
- Geleskey, A., King, R. D., Corte, D., Pinto, P., & Ledward, D. A. (1998). The kinetics of cooked meat haemoprotein formation in meat and model systems. *Meat Science*, 48(3/4), 189–199.
- Guan, D. S., Plotka, V. C. F., Clark, S., & Tang, J. M. (2002). Sensory evaluation of microwave treated macaroni and cheese. *Journal of Food Processing and Preservation*, 26(5), 307–322.
- Haard, N. F. (1992). Biochemistry and chemistry of color and color changes in seafoods. In G. J. Flick & R. E. Martin (Eds.), *Advances in seafood biochemistry: Composition and quality* (pp. 305–360). Lancaster, PA: Technomic Publishing Company Inc.
- Harris, P. V., & Shorthose, W. R. (1988). Meat texture. In R. A. Lawrie (Ed.), *Developments in meat science* (Vol. 4, pp. 245–296). Elsevier.
- Hart, F. L., & Fisher, H. J. (1971). *Modern food analysis*. New York: Springer, pp. 2–3.
- Hui, Y. H., Cross, N., Kristinsson, H. G., Lim, M. H., Nip, W. K., Siow, L. F., et al. (2006). Biochemistry of seafood processing. In Y. H. Hui (Ed.), *Food biochemistry & food processing* (pp. 351–378). Ames, IA: Blackwell Publishing Professional.
- Iverson, S. J., Lang, S., & Cooper, M. (2001). Comparison of the Bligh and Dyer and Folch methods for total lipid determination in a broad range of marine tissue. *Lipids*, 36, 1283–1287.
- Kessler, H. G., & Fink, R. (1986). Changes in heated and stored milk with an interpretation by reaction kinetics. *Journal of Food Science*, 51, 1105–1111.
- Kong, F. B., Tang, J. M., Rasco, B., Crapo, C., & Smiley, S. (2007). Quality changes of salmon (*Oncorhynchus gorbuscha*) muscle during thermal processing. *Journal of Food Science*, 72(2), S103–S111.
- Lau, M. H., Tang, J. M., Taub, I. A., Yang, T. C. S., Edwards, C. G., & Mao, R. (2003). Kinetics of chemical marker formation in whey protein gels for studying microwave sterilization. *Journal of Food Engineering*, 60(4), 397–405.
- Laroche, M. (1980). Weight loss during cooking. Its nature and mechanisms. *Viandes et produits carnés*, 1(1), 26–28.
- Leander, R. C., Hedrick, H. B., Brown, M. F., & White, J. A. (1980). Comparison of structural changes in bovine longissimus and semitendinosus muscles during cooking. *Journal of Food Science*, 45(1), 1–6, p. 12.
- Lund, D. B. (1977). Design of thermal processes for maximum nutrient retention. *Food Technology*, 71–78.
- Offer, G., Restall, D., & Trinick, J. (1984). Water-holding in meat. In A. J. Bailey (Ed.), *Recent advances in chemistry of meat* (pp. 71–86). London: The Royal Society of Chemistry.
- Ofstad, R., Kidman, S., & Hermansson, A. M. (1996). Ultramicroscopical structures and liquid loss in heated cod (*Gadus morhua* L.) and salmon (*Salmo salar*) muscle. *Journal of the Science of Food and Agriculture*, 72(3), 337–347.
- Ofstad, R., Kidman, S., Myklebust, R., & Hermansson, A. M. (1993). Liquid holding capacity and structural changes during heating of fish muscle: Cod (*Gadus morhua* L.) and salmon (*Salmo salar*). *Food Quality*, 12, 163–174.
- Palka, K., & Daun, H. (1999). Changes in texture, cooking losses, and myofibrillar structure of bovine *M. semitendinosus* during heating. *Meat Science*, 51(3), 237–243.
- Pandit, R. B., Tang, J., Mikhaylenko, G., & Liu, F. (2006). Kinetics of chemical marker M-2 formation in mashed potato—a tool to locate cold spots under microwave sterilization. *Journal of Food Engineering*, 76, 353–361.
- Peleg, M., Engel, R., Gonzalez-Martinez, C., & Corradini, M. G. (2002). Non-Arrhenius and non-WLF kinetics in food systems. *Journal of the Science of Food and Agriculture*, 82, 1346–1355.
- SAS User's Guide: Statistics, 6th ed. (1996). Cary, NC: SAS Institute Inc.
- Taoukis, P. S., Labuza, T. P., & Saguy, I. S. (1997). Kinetics of food deterioration and shelf life prediction. In E. Rotstein, K. J. Valentas, & R. P. Singh (Eds.), *Handbook of food engineering practice*. New York: CRC Press.
- Viberg, U., Ekstrom, G., Fredlund, K., Oste, R. E., & Sjöholm, I. (1997). A study of some important vitamins and antioxidants in a blackcurrant jam with low sugar content and without additives. *International Journal of Food Science and Nutrition*, 48(1), 57–66.
- Wang, Y., Lau, M. H., Tang, J., & Mao, R. (2004). Kinetics of chemical marker M-1 formation in whey protein gels for developing sterilization processes based on dielectric heating. *Journal of Food Engineering*, 64(10), 111–118.
- Whistler, R. L., & Daniel, J. R. (1985). Carbohydrates. In O. R. Fennema (Ed.), *Food chemistry* (pp. 98–99). Marcel Dekker.